

City of Tukwila

**Tukwila International Boulevard
Design Manual**

January 1999

Prepared in conjunction with MAKERS architecture and urban design

Table of Contents

INTRODUCTION	1
PURPOSE.....	1
BACKGROUND.....	1
APPLICATION OF THE MANUAL.....	2
THE REVIEW PROCESS.....	2
ORGANIZATION	3
1. SITE DESIGN	5
A. SITE DESIGN CONCEPT	5
B. RELATIONSHIP TO STREET FRONT	8
C. STREET CORNERS	11
D. CONTINUITY OF SITE WITH ADJACENT SITES	13
E. SHARED FACILITIES.....	15
F. SITE DESIGN FOR SAFETY	16
G. SITING AND SCREENING OF SERVICE AREAS	23
H. NATURAL FEATURES AND SENSITIVE AREAS	24
I. SURFACE STORMWATER DETENTION FACILITIES	30
J. PEDESTRIAN CIRCULATION.....	34
K. PEDESTRIAN AMENITIES	39
L. VEHICULAR CIRCULATION.....	41
M. PARKING.....	44
2. BUILDING DESIGN	45
A. ARCHITECTURAL CONCEPTS.....	45
B. ARCHITECTURAL RELATIONSHIPS	50
C. BUILDING ELEMENTS, DETAILS, AND MATERIALS	57
D. PEDESTRIAN-ORIENTED FEATURES	64
E. MECHANICAL EQUIPMENT	68
3. LANDSCAPE DESIGN	70
A. LANDSCAPE DESIGN.....	70
B. PLANTING DESIGN.....	75
4. SIGNS.....	77
A. SIGNAGE CONCEPT	77
B. SIGN PLACEMENT.....	79
C. SIGN DESIGN	81
APPENDIX A:	83
DEFINITIONS	83
APPENDIX B:	87
TUKWILA INTERNATIONAL BOULEVARD PLANT PALETTE.....	87

Introduction

Purpose

The purpose of the Tukwila International Boulevard Design Manual is to illustrate the community's expectations for mixed-use, commercial and light industrial development in the Tukwila International Boulevard area. The Manual includes design criteria, by which decisions will be made on development proposals, and design guidelines, which provide examples and guidance as to how to meet the intent of the criteria.

An important goal of the community is to establish and promote a built environment that is functional and attractive for both motorists and pedestrians, and these criteria and guidelines will aid in achieving that goal. For example, building facades that are visually interesting are required, and prominent building entries are encouraged. Walkways connecting the building entrances to the street are required, and pedestrian amenities such as benches, special lighting and areas for display are encouraged. These provisions will help create a more pleasant environment in which to walk, shop and do business in the area.

Another important goal of the community is to support and revitalize the business community in the Tukwila International Boulevard area. To this end, and in recognition of some of the unique physical conditions that exist in the Tukwila International Boulevard area, certain development standards will be waived under specific circumstances. For example, where businesses would benefit from combining their parking areas, this is made possible by waiving the requirement for landscaping and setbacks in this area. The City wishes to promote more effective use of land and support redevelopment wherever possible along Tukwila International Boulevard.

Another goal of the community is to increase safety. Many of the design criteria and guidelines in areas of site design, building design and landscape design are designed to achieve this goal. Examples include increased site lighting, site and building design that allows for site surveillance, and landscape design that does not obscure views from the street into parking and service areas, and between motorists and pedestrians.

The criteria and guidelines do not specify a particular style of architecture or design, but are intended to guide applicants in increasing the efficiency of their sites; coordinating site design, building placement and landscape design elements with neighboring sites and within building parcels; and creating an appearance of greater consistency and design quality along the corridor.

Background

Tukwila International Boulevard South, also known as Highway 99, was once the main, north-south route in the Puget Sound area, and it initially developed as a part of unincorporated King County. In 1991 and 1992 the area was annexed to the City of

Tukwila and upon community mandate, the revitalization of the area became the City's number one priority.

The Tukwila International Boulevard area is unique to the City because of its proximity to schools and homes, and because of its supply of neighborhood stores and businesses. From a business perspective, it is unique because of the excellent arterial that gives the area its name - Tukwila International Boulevard - and its proximity to the regional interstate highway system, Sea-Tac Airport, Boeing Field, and the City of Seattle.

The City is concerned about the safety of pedestrians and motorists using Tukwila International Boulevard, and the quality and type of development that occurs in the corridor. It is committed to improving the Tukwila International Boulevard roadway, adding curbs, gutters, sidewalks and other amenities, and bringing surrounding development and signage up to City standards. The City is also concerned about the people who have businesses in the area, who work or do business in the area, and who live in the surrounding neighborhoods. Among the safety and social programs that are being implemented, are the "Crime Free Multifamily Housing," program, a community oriented policing program, and a new "Neighborhood Resource Center," which is manned by members of the Police Department and volunteers from the community. The City has also instituted a Enterprise Zone for this area, which allows the City to pay for public development costs associated with redevelopment.

These Design Criteria and Guidelines implement the City's Comprehensive Plan policies that envision and guide the future of this area for businesses and residents. Tukwila's Comprehensive Plan was developed with extensive involvement from the community over the 1991 to 1995 time frame, and was adopted in December 1995. These Design Criteria and Guidelines have been developed with the help of the Highway 99 Task Force, in conjunction with their work with the Pacific Highway Revitalization Plan. (In November 1998, the Tukwila City Council changed the street name of Pacific Highway, also known as State Route 99, to Tukwila International Boulevard.) The major parts of the Plan include the street improvements noted above, these Design Criteria and Guidelines, which guide private development, and the revitalization strategies, some of which are mentioned above. This document is an important part of the overall revitalization of the Tukwila International Boulevard area.

Application of the Manual

The Review Process

The City of Tukwila has had a design review process and Board of Architectural Review (BAR), which oversees application of the Design Criteria and Guidelines, since 1982. These criteria and guidelines will be adopted as a part of the Zoning Code chapter entitled "Board of Architectural Review," and will govern development proposals in three zoning districts in the Tukwila International Boulevard project area.

Certain project proposals in these three zones, the Regional Commercial (RC), Neighborhood Commercial Center (NCC), and Mixed Use Office (MUO) zones, are subject to the Design Review process and project review thresholds stipulated in the Zoning Code, and the criteria and guidelines in this Manual. Multi-family projects, hotel/motel projects and the residential portion of mixed use projects within the Tukwila International Boulevard project area are also subject to the Multi-family Design Manual referenced in TMC 18.60.053.

The Board of Architectural Review, which consists of seven appointed members from the community, will use this Design Manual to approve, approve with conditions, or deny proposed development projects. In addition, project proposals must meet all other applicable City codes and adopted standards, with the possibility of the waivers outlined in this document.

Organization

The Tukwila International Boulevard Design Manual is organized in four sections, covering Site Design, Building Design, Landscape Design and Signs. Within each section are a number of subject areas, covering such issues as pedestrian circulation, architectural relationships, planting design and sign placement. For each subject area, there are one or more Design Criteria, which are general in nature. The Design Criteria explains requirements for development proposals. They are the decision criteria by which the Board of Architectural Review will decide whether to approve, condition or deny a project.

The Design Guidelines, which augment each Design Criteria, provide guidance to the project applicant developing the project, to City staff in reviewing a project proposal, and to the Board of Architectural Review in determining whether the project meets the Design Criteria. The Design Guidelines consist of both written descriptions and illustrations. They provide:

- Further explanation of the requirements which must be met to fulfill the intention(s) of the Design Criteria;
- Additional considerations for project design that may be advantageous to the project applicant, depending on specific site conditions;
- Additional considerations for project design that may be advantageous to the community in meeting the goals of the Comprehensive Plan for this area; and/or
- Possible or alternative design solutions that meet the intent of the Design Criteria.

Appendix A of the Design Manual contains a Definitions section for common terms used in this document, and requirements for some special terms, such as Pedestrian Friendly Facades and Pedestrian Oriented Space. Appendix B consists of a plant list for the Tukwila International Boulevard corridor, to be used in front yard landscaping.

Further information about the City's design review process can be obtained at the Department of Community Development.

Figure 1: This map of the Tukwila International Boulevard study area shows the commercial zoned properties that are subject to review with the Tukwila International Boulevard Design Manual.

1. Site Design

A. Site Design Concept

DESIGN CRITERIA

1. Organize site design elements to provide an orderly and easily understood arrangement of building, landscaping, and circulation elements that support the functions of the site.

INTENT

- To encourage development that displays a clear and unifying site organization and composition of buildings and landscape features.
- To upgrade the overall visual appearance of the Tukwila International Boulevard area.
- To support site design that promotes ease of use, comfort and safety for employees, visitors and residents.

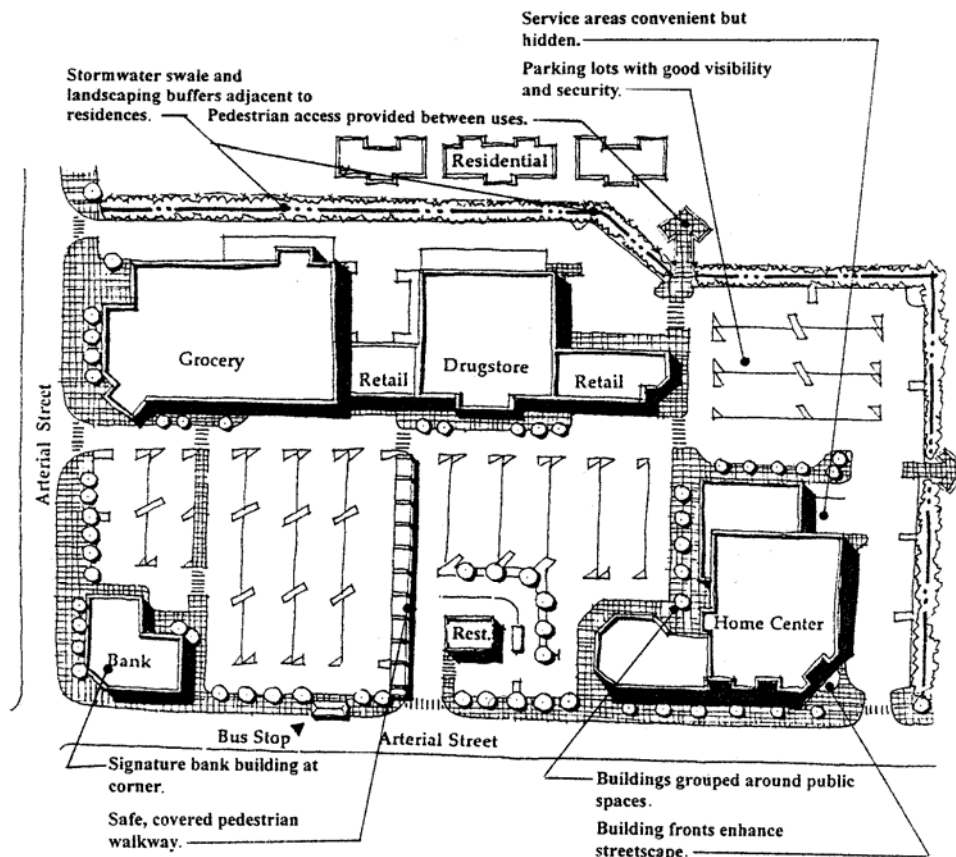

Figure 2: A well-conceived site plan integrates pedestrian and vehicle circulation, relates to neighboring sites, creates functional open space, and promotes visual identity.

Building is not connected to public sidewalk or adjacent sites with walkways

No buffer zone for pedestrians between front doors and parking

No entrance to building from street.

No interior lot sidewalks

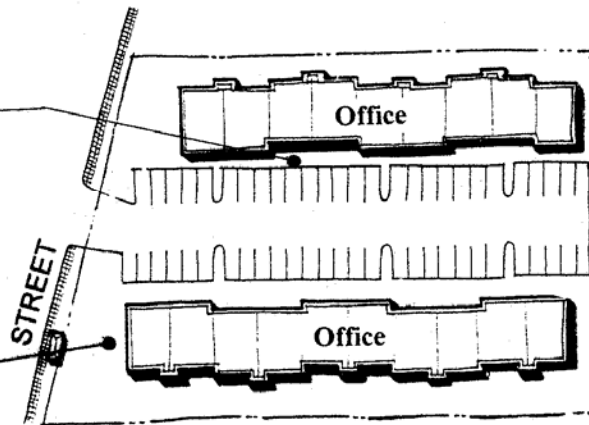

Figure 3: This site layout is lacking pedestrian connections and amenities

Building is integrated and connected with parking, public sidewalk and adjacent sites.

An attractive pedestrian courtyard is the dominant feature.

Walkways and landscape features provide clear pedestrian circulation patterns.

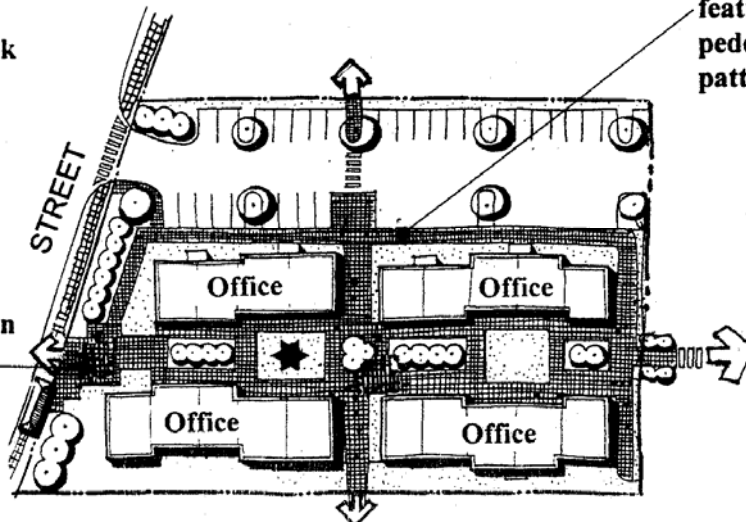

Figure 4: This design scheme illustrates a well-conceived, pedestrian-oriented site design concept.

GUIDELINES

Site planning is the arrangement of landscaping, open spaces, buildings, circulation elements, and other features to support the goals of the development. Each of these elements is interrelated. A well-conceived site design concept and effective site plan should address the following:

- Demonstrate how the elements of the site relate to the street front;
- Provide for compatibility with adjacent sites;
- Provide protection for natural features;
- Respond to climatic factors such as prevalent wind patterns, and sun and shade;
- Enhance street corners;
- Promote safety;
- Incorporate service areas and stormwater facilities in a non-obtrusive manner;
- Provide convenient pedestrian and vehicle circulation connecting on-site activities with adjacent pedestrian routes and streets.

B. Relationship to Street Front

DESIGN CRITERIA

1. **Organize site design elements to create a distinct street edge, and minimize parking between structures and street.**

INTENT

- To create an active, safe pedestrian environment.
- To upgrade the visual appearance of the Tukwila International Boulevard area.
- To unify the streetscape by providing a consistent 'edge' to the street.

GUIDELINES

One of the primary purposes of these guidelines is to ensure that private development creates a more pedestrian friendly environment, and that private development reinforces and augments the public street improvements for pedestrians. To achieve this goal, incentives are established for private property owners to locate their buildings closer to the public right-of-way.

Public sidewalks. Public sidewalks are required along all street frontages - 12 foot wide sidewalks along Tukwila International Boulevard and 8 foot wide sidewalks along all other streets. Public landscaping occurs within these sidewalks. Where sidewalks do not exist, applicants will be required to install them. In most cases, sufficient width exists to construct the sidewalk within the public right-of-way; however, if there is not sufficient right-of-way, then applicants will be required to construct a sidewalk that meets width standards and dedicate the area to the City.

There may be some situations where the traffic lane adjacent to the sidewalk or proposed sidewalk is substandard in width. In this case, private property owners must both provide for the standard lane width and the standard sidewalk width.

Building setbacks. Projects are encouraged in which buildings are sited adjacent to or close to the public sidewalk, to create a more pedestrian oriented environment and a strong street edge. As an incentive to site structures in this location, the required landscape strip and setback will be waived, provided that:

- It is approved as part of overall design approval; and
- Pedestrian oriented space (see Appendix A, Definitions) is provided.

Note: If vehicle circulation areas, parking, or outdoor storage is located between the building and the public right-of-way, the landscape strip will not be waived.

Note: See Zoning Code for outdoor storage screening requirements.

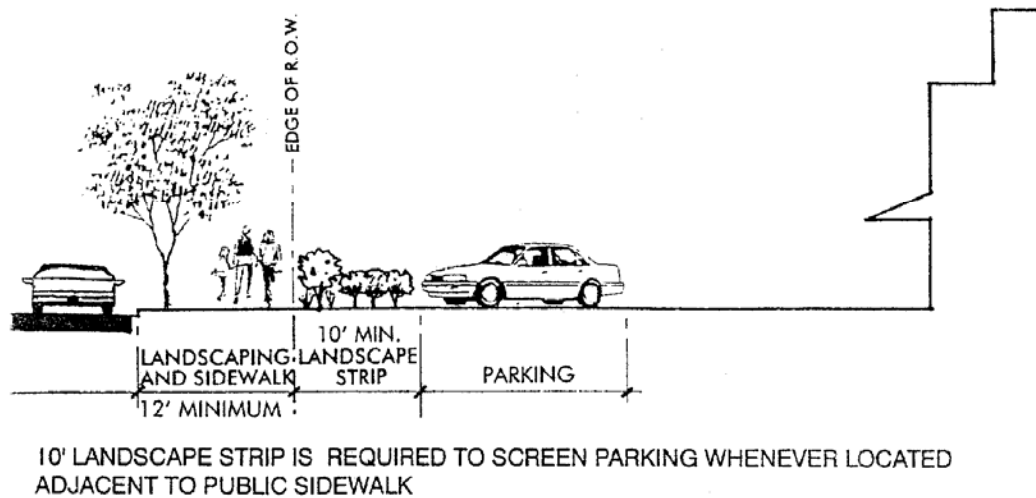
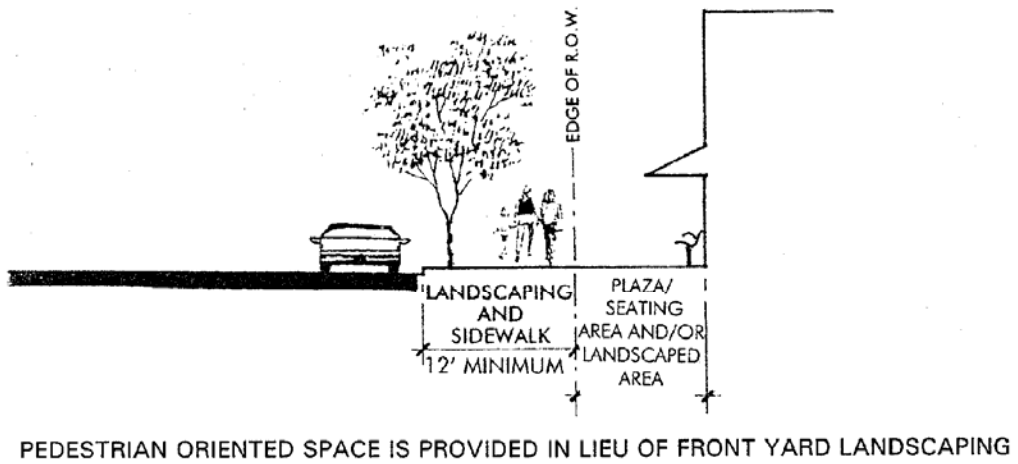
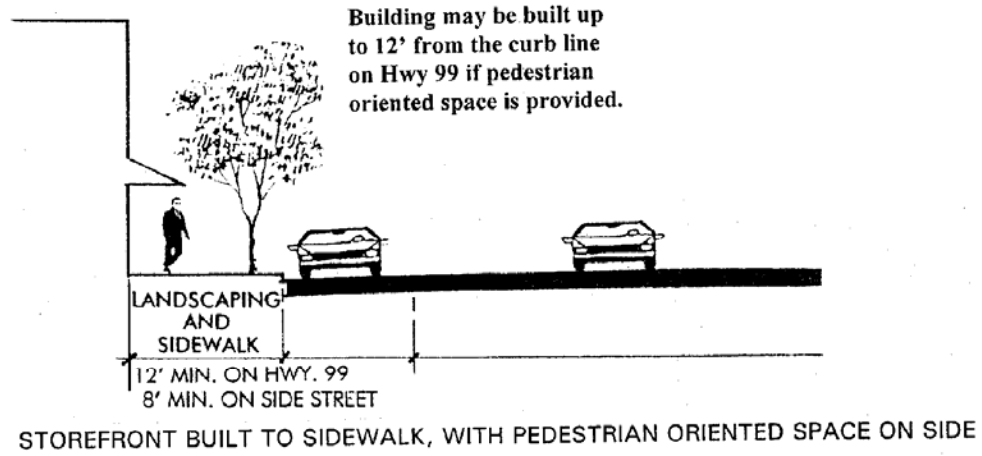

Figure 5: Relationships to street

Parking areas. Development proposals in which parking is placed to the side or in back of the building, or a combination of these solutions, are encouraged. Two or more small parking areas are preferable to one large parking area, particularly if one parking area is located between the building and the public street (Criteria 1.M.1., “Parking.”)

DESIGN CRITERIA

2. Orient at least one building entry to a major public street.

INTENT

- To ensure that building access is visible and accessible to pedestrians and drivers from the sidewalk and street.
- To ensure that building entrances are a prominent element of the streetscape.

GUIDELINES

In general, Tukwila International Boulevard is considered the major public street in this area.

Developments in which the major building entry faces the major public street are encouraged. Primary entries that are located on a facade not facing the major public street are allowed, provided that the entry is *visible* from the major public street.

For design treatment of entries, see Criteria 2.D.3., “Pedestrian-Oriented Features.”

C. Street Corners

DESIGN CRITERIA

1. **Emphasize the importance of street corners through building location, the provision of pedestrian access, special site features and/or landscape features.**

INTENT

- To increase the prominence of buildings on street corners.
- To add visual interest to the streetscape.
- To improve access to buildings located on corner lots.

GUIDELINES

Buildings are encouraged to locate within 15 feet of the back side of the public sidewalk or right-of-way. When buildings are located within this area, pedestrian-oriented space or landscaping must be provided between the building and sidewalk, or elsewhere on the site (See Appendix A for the definition of pedestrian-oriented space.)

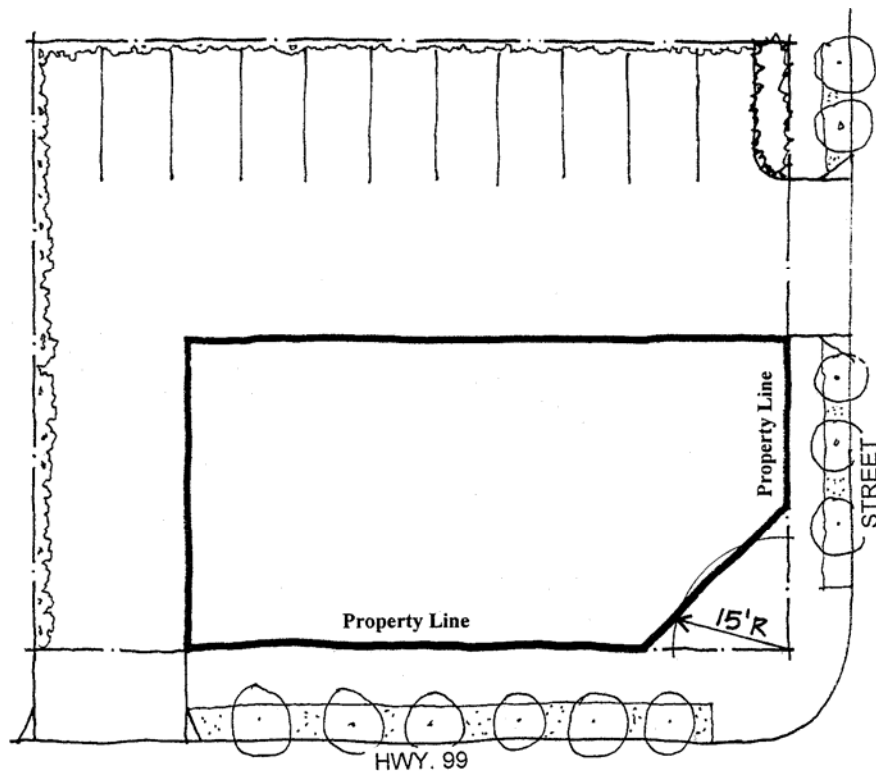

Figure 6: This building is located within 15 feet of the right-of-way line. The corner of the building is notched to provide a necessary sight distance triangle.

Where a building is *not* located within 15 feet of the back side of the public sidewalk or public right-of-way, one of the following must be provided in addition to landscaping or pedestrian-oriented space:

- a) Provide a pedestrian walkway from the corner to the building entry.
- b) Enhance the corner by installing additional substantial landscaping, in addition to required landscaping (at least 200 square feet, with trees and shrubs or ground cover) at or near the corner of the lot.
- c) Construct a decorative screen wall, a trellis, or other continuous architectural element at least 20 feet long along the front property line (Note: For security purposes, walls within front landscape strip should not be over 3 feet in height).
- d) Install a monument sign, enhanced by additional landscaping (provided that the sign meets the other provisions of this Manual and the Tukwila Sign Code.)

Note: Ensure that vehicle sight distances are adequate for safe crossing and turning movements.

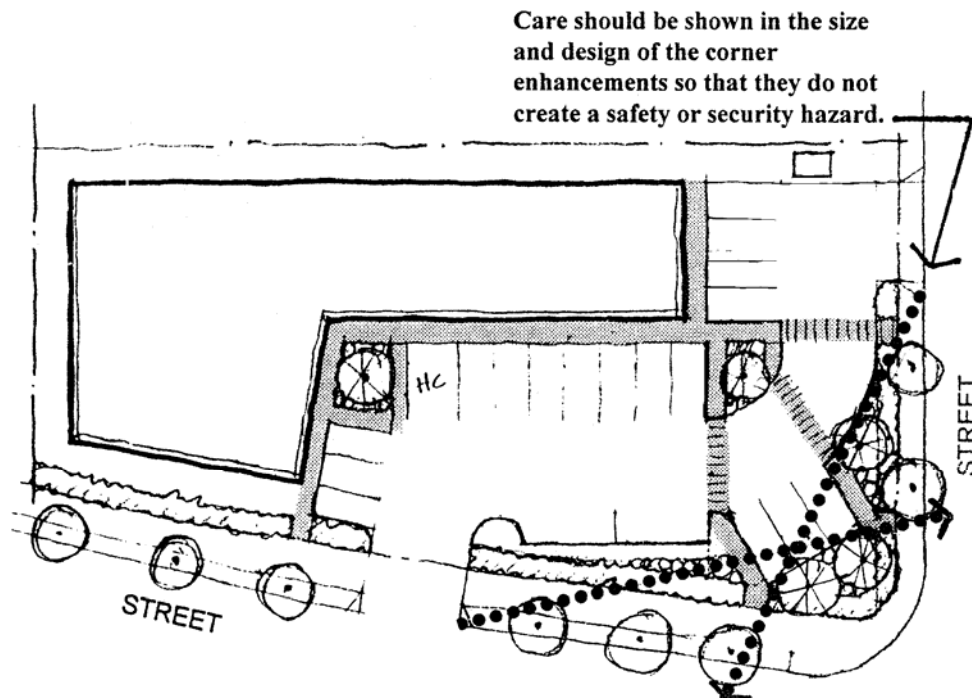

Figure 6b: Provide direct pedestrian connections to building entrances and landscape enhancements when buildings are set back from intersections.

D. Continuity of Site with Adjacent Sites

DESIGN CRITERIA

1. **Maintain visual and functional continuity between the proposed development and adjacent and neighboring properties through setbacks, building massing, circulation and landscaping, where appropriate.**

INTENT

- To maintain a visually continuous building line, where appropriate.
- To promote physical connections between sites.
- To promote appropriate transitions between developments.

GUIDELINES

Building Setbacks: Consider the building setbacks of neighboring structures when establishing setbacks. Continuity along the 'edge' created by structures reinforces the spatial qualities of the street, reinforces the street edge, and ensures that all structures have equal visibility from the street.

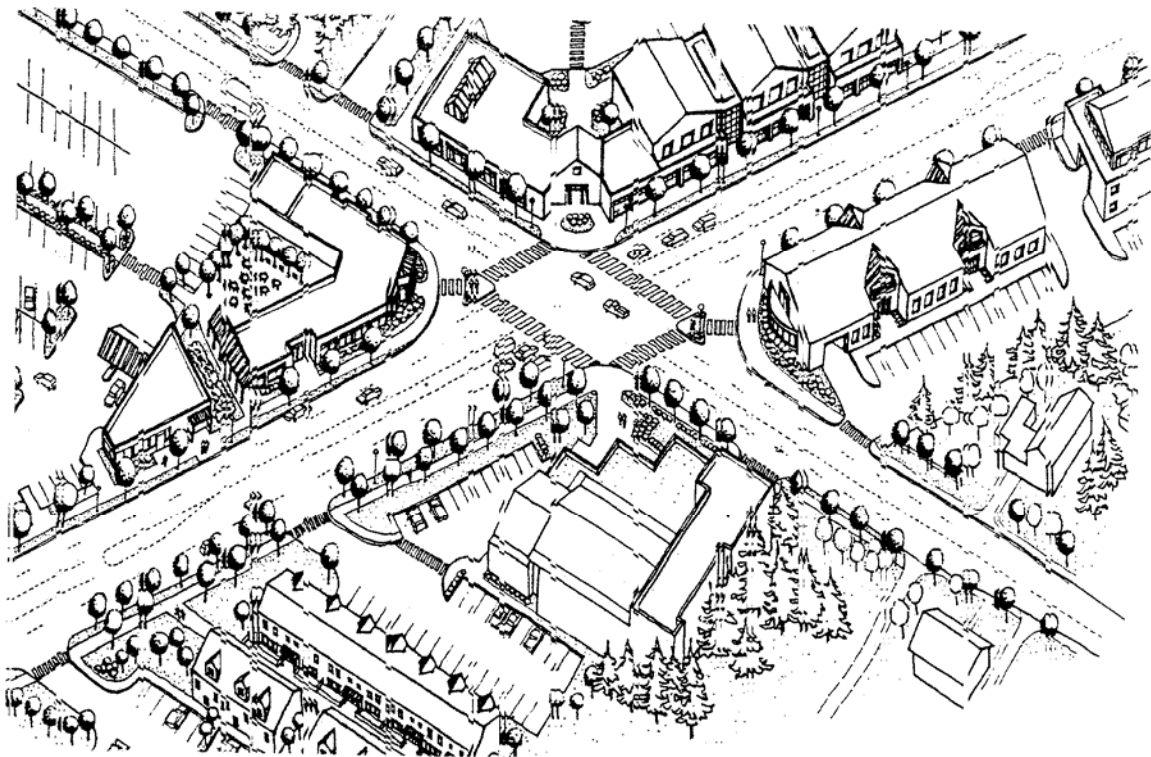

Figure 7: Compatibility with adjacent sites can be achieved by scaling buildings to relate to nearby structures. Repeating elements of streetscape features and plantings within the site and providing pedestrian access can also help achieve compatibility with surroundings.

Massing of Structures: Consider the mass and bulk of the proposed buildings in relation to both existing development and the design direction provided by the Comprehensive Plan, Zoning Code and these Design Criteria. In some areas within the Tukwila International Boulevard area, increased building density is encouraged. In other areas, new development is encouraged that is similar in massing to existing structures (see Criteria 2.B.1., “Architectural Relationships.”)

Location of Pedestrian/Vehicular Circulation Elements: Provide connections to existing and planned sidewalks in the surrounding area, where appropriate. Ensure that on-site vehicular circulation is compatible with street circulation and pedestrian walkways. Take advantage of opportunities for combined driveways and parking (see Criteria 1.E.1., “Shared Facilities.”)

Landscaping: Take advantage of opportunities for combining site landscaping with landscaping on adjacent lots to create unified landscape areas in front yards and reinforce continuity of the street edge. Use plant materials from the Tukwila International Boulevard plant palette to augment landscaping along public rights-of-way.

E. Shared Facilities

DESIGN CRITERIA

- 1. Incorporate opportunities for joint development of sites where there is potential for common building walls, shared driveways, landscaping, or other shared facilities.**

INTENT

- To promote coordinated development and/or joint development between adjacent properties.
- To promote efficient use of resources that may be shared, such as parking and driveways.

GUIDELINES

Applicants are encouraged to take advantage of opportunities for joint development with adjacent sites where commercially zoned lots abut each other and where the efficiency or appearance of a development would be improved as a result. Opportunities may include shared driveways, shared parking, party wall structures, or combined landscape areas. Benefits may include a more efficient use of land, greater development density, and the ability to provide additional amenities. These benefits must accrue without compromising the privacy and buffer treatment between commercial and residential districts.

As an incentive, side yard setbacks and side yard landscaping for that portion of the site used for shared facilities will be waived when adjacent owners jointly develop party wall structures, common driveways, and/or shared parking, provided that:

- a) The amount of landscaping waived is placed elsewhere on the site;
- b) The waiver is approved as part of overall design review approval; and
- c) Documentation governing the future of the shared use is provided to the satisfaction of the City.

Note: See Zoning Code for procedures for establishing shared parking.

F. Site Design for Safety

DESIGN CRITERIA

- 1. Minimize conflicts between drivers and pedestrians through the siting of structures, location of circulation elements, landscape design, and placement of signs.**

INTENT

To ensure that the organization of site elements contributes to the safety of pedestrians on the site.

GUIDELINES

The following are ways in which vehicle/pedestrian conflicts may be minimized. Incorporate the following methods for protecting pedestrian safety, where appropriate:

- Limit the number of potential encounters between pedestrians and vehicles through site design.
- Where pedestrian and motorist paths must cross, provide adequate sight distance.
- Ensure that landscaping at crosswalks and other locations where vehicles and pedestrian intersect does not block pedestrians and drivers' views.
- Provide raised sidewalks, crosswalks and pedestrian walkways where possible; or provide at-grade walkways protected by curbs and/or landscaped areas.
- Provide distinctively marked pedestrian routes through parking lots, using vertical design elements, special paving, painted crosswalks or signage.
- Separate service vehicle access and loading zones from pedestrian areas where possible.
- Use on-site directional signs to clearly mark vehicular routes.

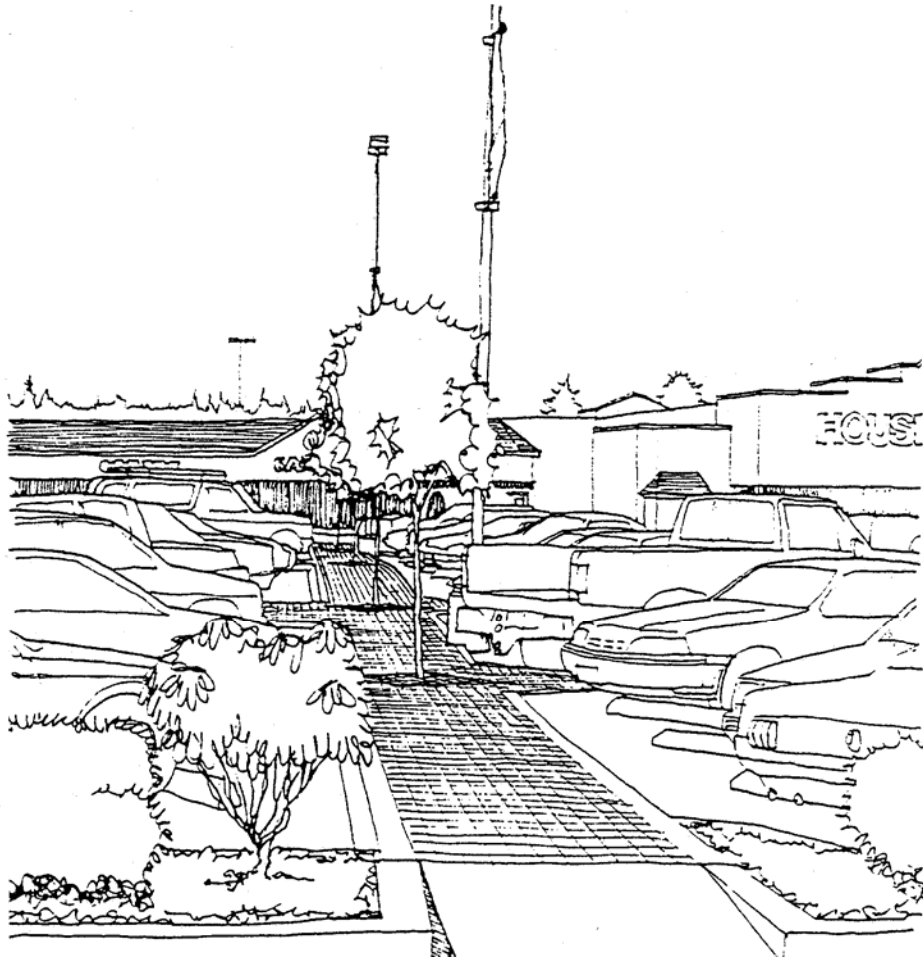

Figure 8: Raised walkways through parking lots increase pedestrian safety.

DESIGN CRITERIA

2. Design and site structures to maximize site surveillance opportunities from buildings and public streets.

INTENT

- To ensure that site design promotes personal safety and property security.

GUIDELINES

Incorporate the following methods to increase personal safety and security, where appropriate:

- Avoid site and building design features that create entrapment areas (e.g. tunnels, long corridors, and opaque fences) in locations with pedestrian activity.
- Ensure that site and building provides sight lines that allow observation of outdoor on-site activities by building occupants and passersby.
- Site buildings so that windows, balconies and entries overlook pedestrian routes, vehicular circulation routes, and parking areas and allow for informal surveillance of these areas, where possible.

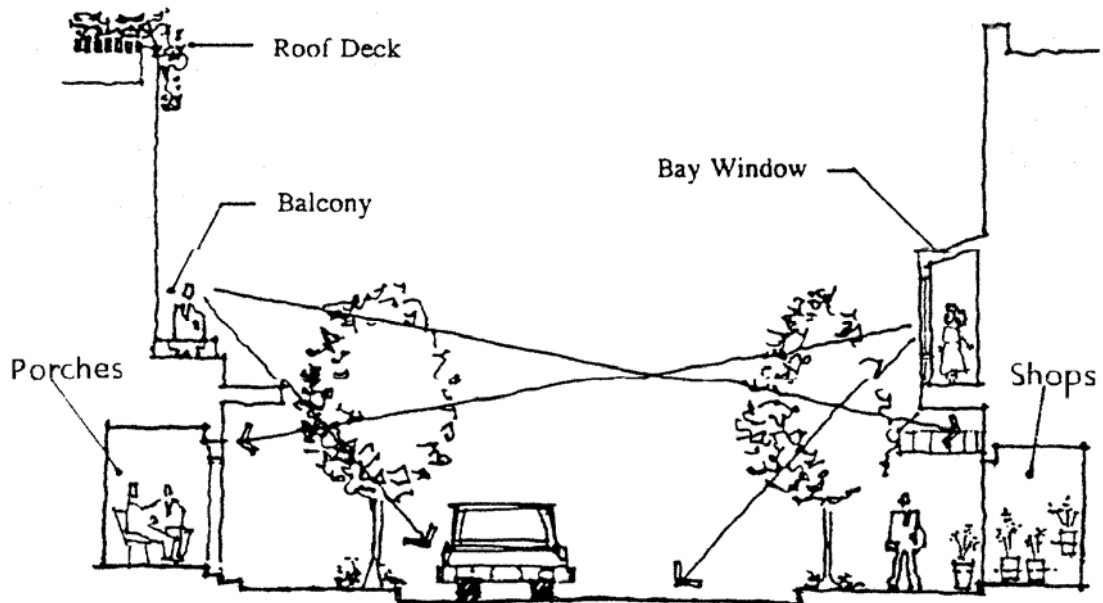
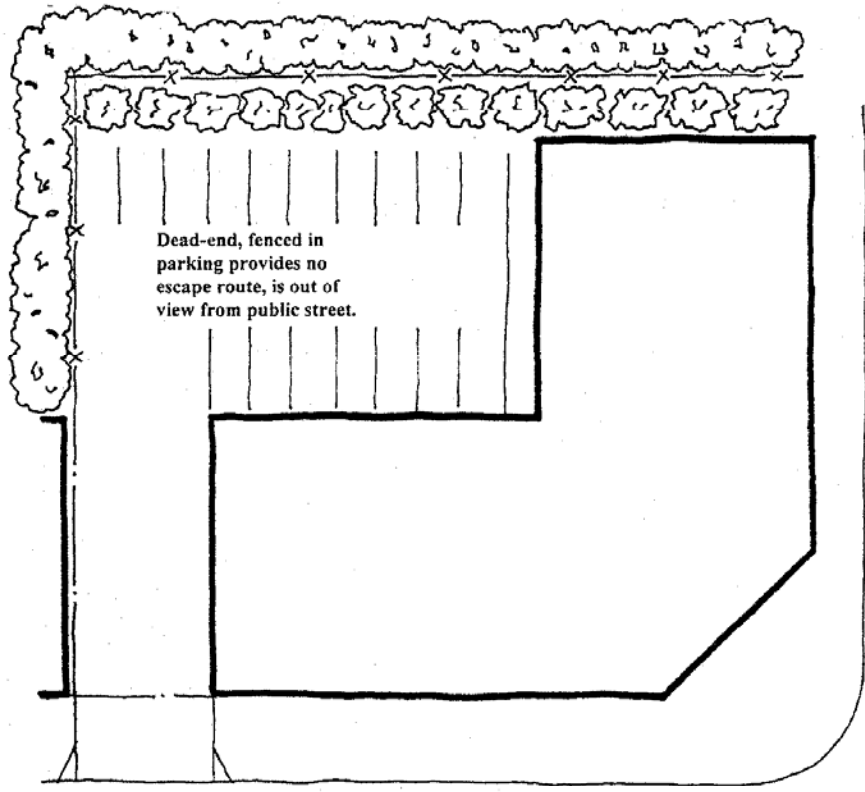
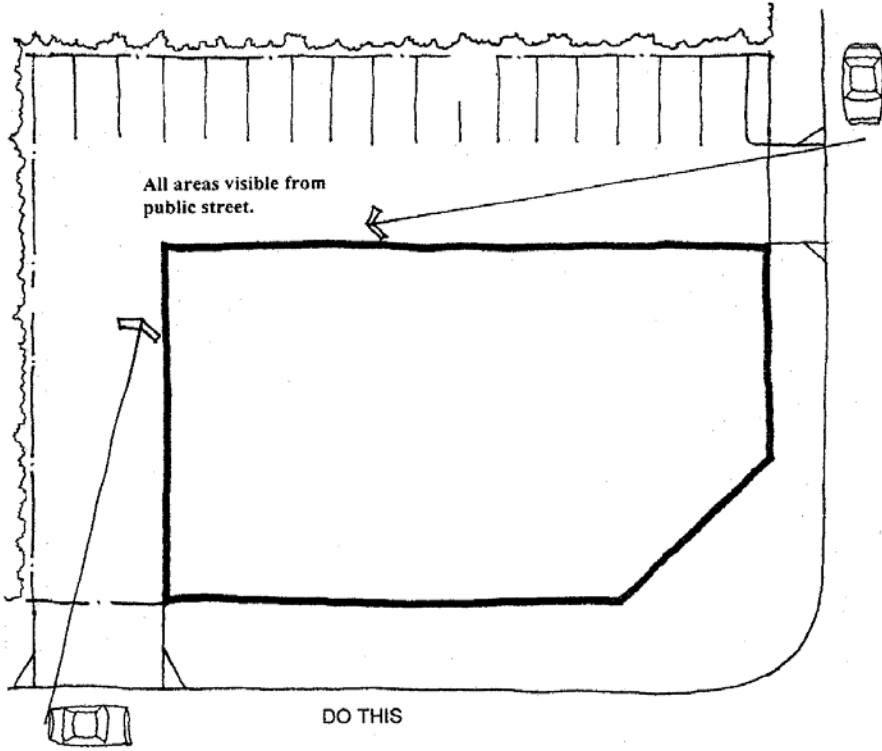

Figure 9: Site planning and building design can promote "eyes on the street" and safety.



DON'T DO THIS



DO THIS

Figure 10: Design the site to avoid creating potential entrapment areas

DESIGN CRITERIA

- 3. Provide adequate lighting levels in all pedestrian areas, including building entries, along walkways, parking areas, and other public areas.**

INTENT

- To ensure that the night-time environment is safe and inviting.
- To ensure that lighting does not interfere with other site functions.

GUIDELINES

Include the following in lighting plans:

- a) Provide an overlapping pattern of light at a height of about 7 feet in lighted areas.
- b) Provide lighting at consistent lumens with a gradual transition to unlighted areas. Avoid creating highly contrasting pools of light and dark areas, which can be temporarily blinding.
- c) Provide lighting at all building entrances, exits and corridors between buildings, especially where doors are recessed.
- d) Design lighting levels so that pedestrians can identify a face 15 yards away, in order to reduce anonymity and to give pedestrians the opportunity to choose another route if they feel unsafe.
- e) Ensure that site lighting is confined to the project site and does not cause glare on adjacent properties.

Note: Place posts and standards so that they do not create hazards for pedestrians or vehicles

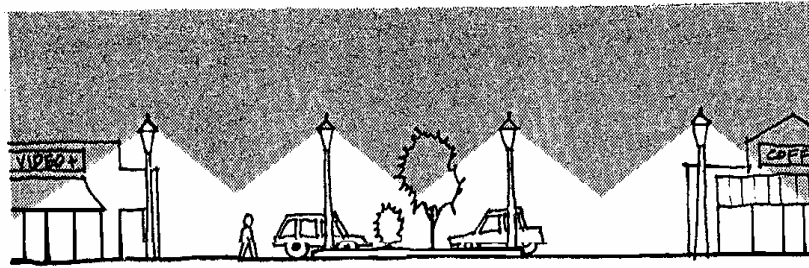

DO THIS

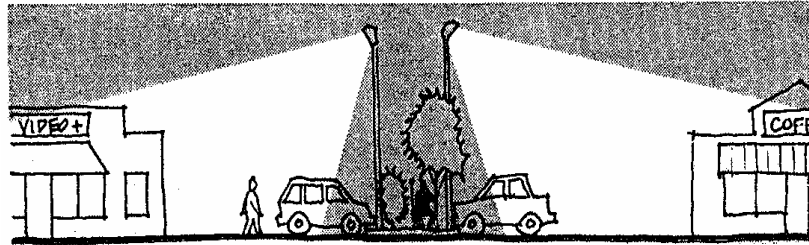

DON'T DO THIS

Figure 11: Smaller-scale lighting standards, 10-15 feet in height, evenly spaced, and at consistent foot-candle levels provide for greater safety. A minimum of 2 foot-candles on the ground is recommended.

DESIGN CRITERIA

4. **Design landscaping so that long term growth will not interfere with site lighting and surveillance.**

INTENT

- To ensure that landscaping does not compromise site lighting and surveillance as it matures.
- To encourage selection of plant materials based on site security needs.

DESIGN GUIDELINES

Include the following in lighting plans to provide for compatibility of landscaping with site lighting:

- a) Ensure that the type and placement of light fixtures in the landscape will allow for achieving site lighting guidelines established in the previous section (Criteria 1.F.3.)
- b) Space landscape elements to allow for long term growth mature without interfering with site lighting; or select plant species considering long term growth characteristics; or
- c) Prune shrubs to allow for adequate surveillance (approximately 3-4 feet in height.) Limb trees to a height that allows visibility under them (approximately 6 feet.)

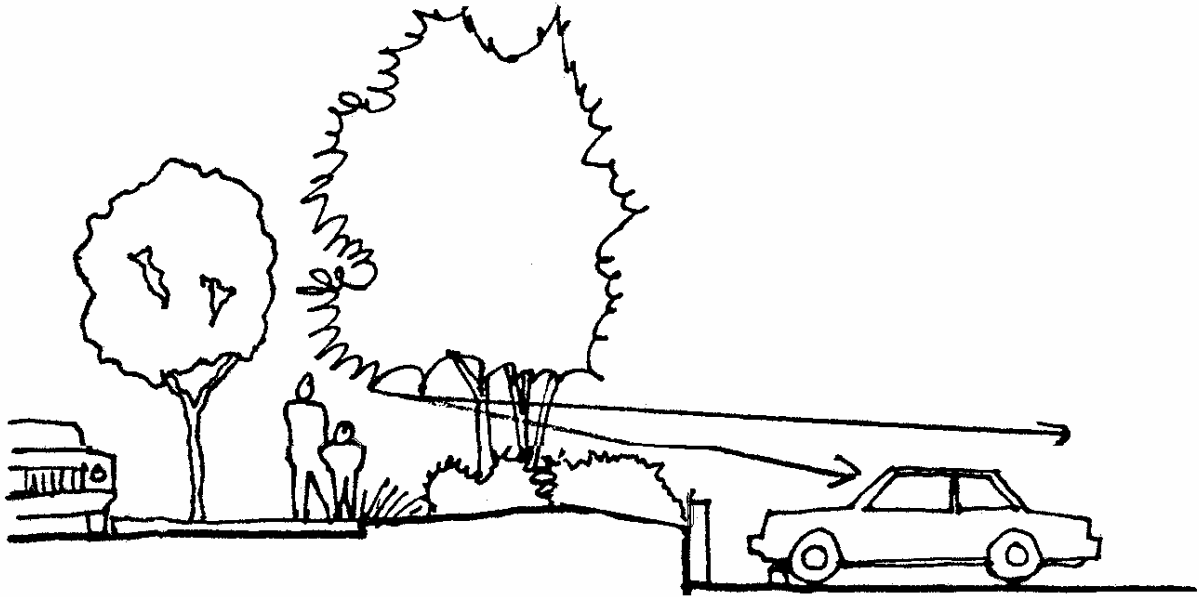

Figure 12: Low bushes and trimmed street trees effectively screen parking, yet still allow visual permeability into the site.

DESIGN CRITERIA

- 5. Use durable, high quality materials in site furnishings and features for ease of maintenance.**

INTENT

- To upgrade the appearance of the Hwy 99 area.
- To minimize maintenance costs.
- To discourage vandalism and misuse.

DESIGN GUIDELINES

Use high quality materials in site furnishings and features, such as walls and paving, that are durable and easily maintained.

Design site features and select furnishings that discourage vandalism. For example, large blank walls encourage vandalism. Furnishings that are easily removed, or that do not convey an image of care, invite misuse.

Use materials that promote safety, such as non-slip walkway surfaces.

G. Siting and Screening of Service Areas

DESIGN CRITERIA

1. **Minimize the visual and aural impacts of service areas such as loading docks, trash and recycling collection points, utility maintenance areas, etc., through site design, landscaping and screening.**

INTENT

- To minimize the visual presence of service areas for businesses, customers and surrounding property owners.
- To minimize potential conflicts between users of service areas, customers and surrounding property owners.
- To ensure continued access to service areas.

GUIDELINES

Service areas include, but are not limited to, trash dumpsters, compactors, ground level mechanical equipment, utility vaults, loading zones, outdoor storage areas, trash and recycling areas, and other intrusive site features.

Locate service areas so that negative visual and auditory (noise) impacts on the street and adjacent properties are minimized.

Avoid siting utility equipment where it displaces significant landscaping, or where serving the equipment would be detrimental to existing landscaping. Provide access to equipment that requires regular servicing.

Provide sufficient screening around service areas, integrating landscaping with other site and adjacent public landscaping, where possible.

Note: See Zoning Code for screening requirements for trash and recycling areas.

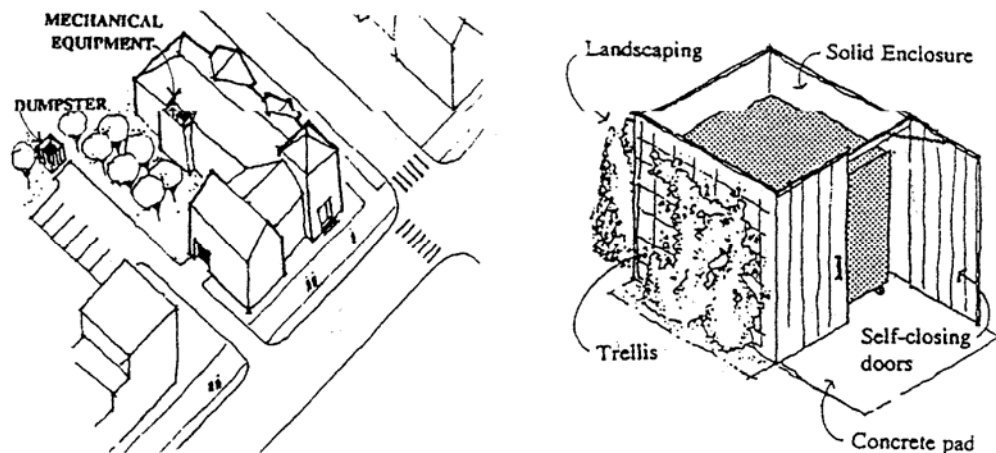

Figure 13: Service areas should be located and screened to minimize their visual, auditory, and olfactory impacts and to avoid their interference with site circulation or other activities.

H. Natural Features and Sensitive Areas

DESIGN CRITERIA

1. **Preserve natural features such as existing topography, significant trees or wooded areas, wetlands and/or watercourses and incorporate them into the overall site, where appropriate.**

INTENT

- To integrate sensitive areas protected by the Tukwila Zoning Code, Chapter 18.45 (Sensitive Areas Overlay) into the site plan, where possible.
- To reduce natural hazards and impacts on the natural environment.
- To encourage development that respects natural land forms.
- To incorporate natural land forms and features as identity features and amenities for the site.

DESIGN GUIDELINES

Preserving and enhancing natural features in conjunction with site planning can allow for physical and/or visual access to these features, which can in turn:

- provide additional amenities on the site;
- preserve these features as assets to the community; and
- minimize the impacts resulting from development.

Preserve, enhance and provide visual access to natural features, where possible. Provide physical access where appropriate.

Provide for a transition from built features to an informal development edge that is in keeping with the adjoining natural features being preserved.

Incorporate existing significant trees and wooded areas into the landscape plan, where possible (see Criteria 3.B.2., “Natural Features.”)

Note: See the Zoning Code Tree Regulations and Sensitive Areas Overlay for requirements for preserving wetlands, watercourses, and significant trees.

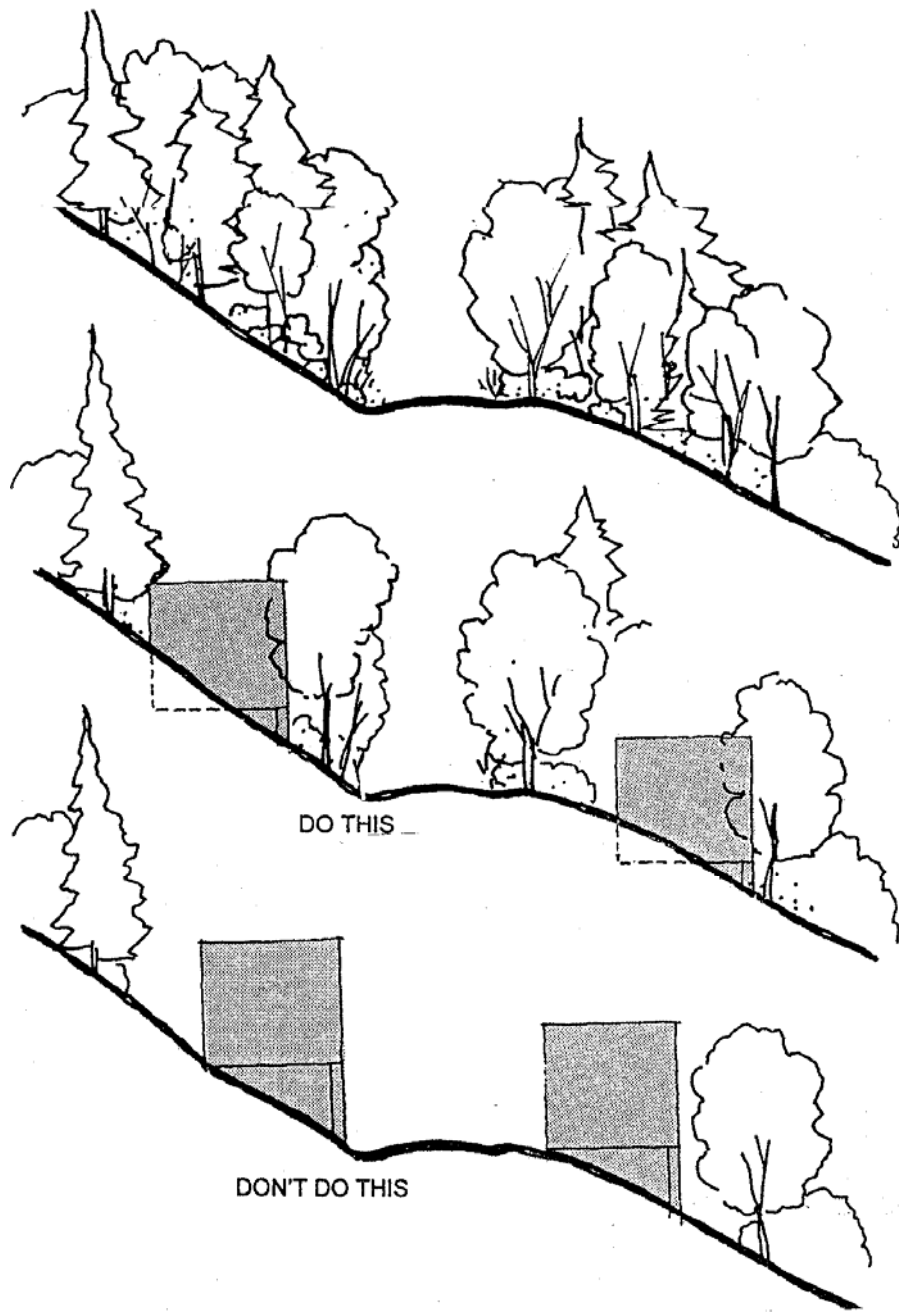

Figure 14: Site buildings in conformance with existing topography. Minimize cutting and filling and the use of retaining walls.

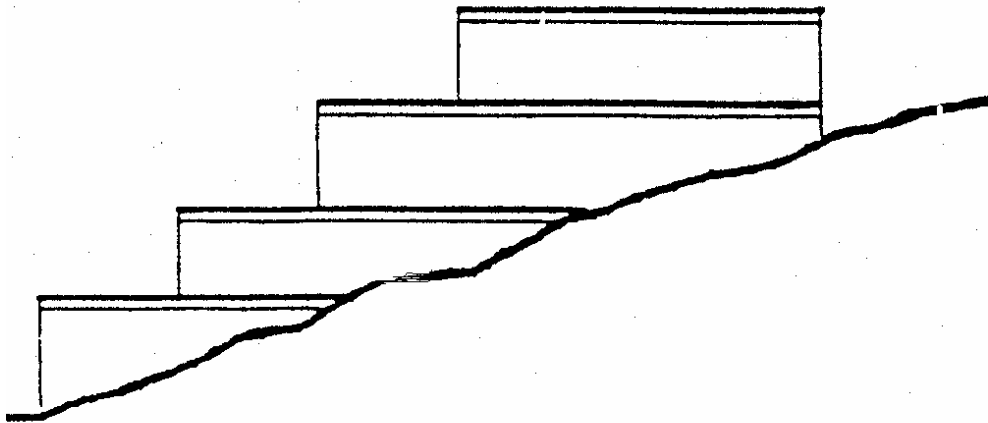

Figure 15: Horizontal building modulation. Following topography helps building mass conform to terrain.



Trees along ridgeline are retained

Buildings are framed by natural vegetation

DO THIS

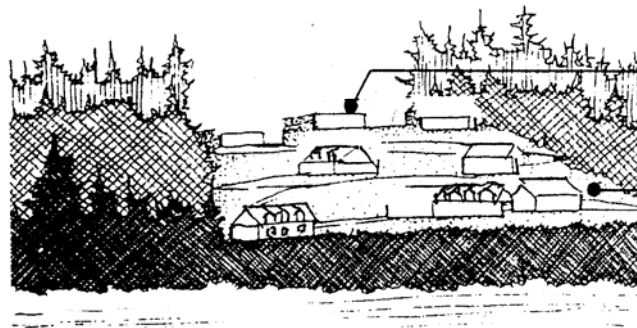

Buildings are built along ridge line

vegetation cleared

Figure 16: Hillsides can be developed while retaining the natural landscape, preserving ridgelines, and providing views.

DESIGN CRITERIA

- 2. Design and site structures on hillsides to minimize the visual and environmental impact of development in these locations.**

INTENT

- To encourage development that minimizes negative visual impacts associated with the development of highly visible hillsides.
- To encourage development that minimizes environmental impacts where there is increased potential for erosion or landslides.
- To encourage sensitive site design that takes into consideration natural land forms.
- To minimize the development costs associated with extensive earthwork.

GUIDELINES

Incorporate the following techniques in development proposals on hillsides where appropriate:

- a) Minimize the amount of grading and filling to reduce potential erosion, drainage, and slope stability problems, and minimize construction costs.
- b) Design access drives, parking areas and building pads with consideration for the existing topography.
- c) Site structures below prominent ridge lines and closer to the toe of the slope (or farther down on the hillside) to minimize clearing, grading and filling and preserve the appearance of natural land forms.
- d) Retain existing wind-firm vegetation along ridge lines.
- e) Retain bands of vegetation that are parallel to the hillside contours, and avoid clearing large areas that are perpendicular to the hillside contours.
- f) Minimize the use and height of retaining walls and use building walls as retaining structures where possible (integrate building design and placement with grading design).

Note: See the Zoning Code for requirements for developing areas of potential geological instability and retaining and replacing significant trees.

DESIGN CRITERIA

- 3. Employ site design techniques that take advantage of and/or enhance visual focal points along the corridor, where feasible.**

INTENT

- To enhance the visual qualities of the highly visible sites east of Tukwila International Boulevard between S. 137th and S. 146th Streets.

GUIDELINES

The curve in Tukwila International Boulevard between S. 137th and S. 146th Streets makes development on the east side of the highway highly visible to pedestrians and drivers traveling in both directions. Projects are encouraged to take advantage of the prominence of these locations in site, building and landscape design.

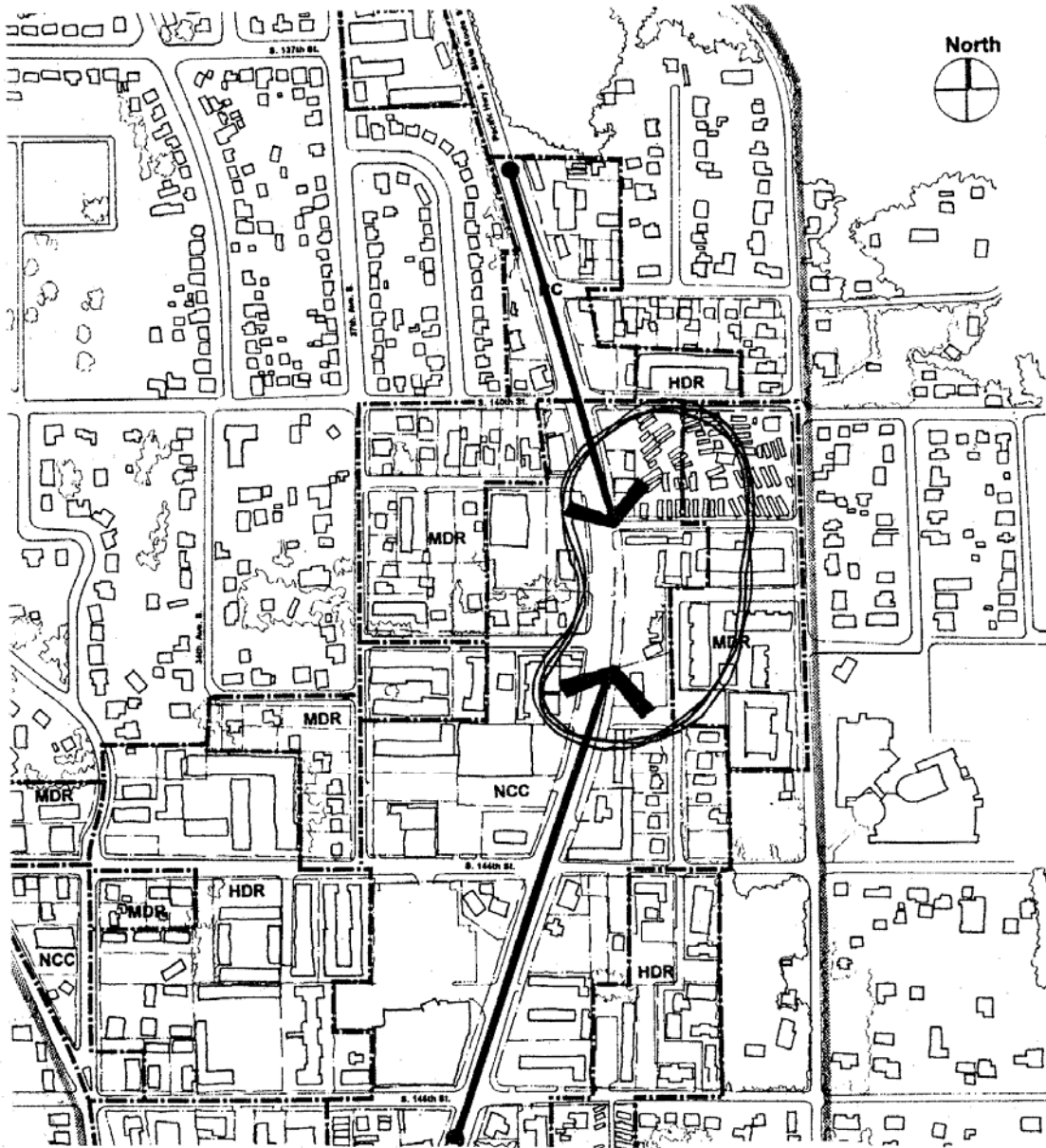

Figure 17: Take advantage of visual focal points along Tukwila International Boulevard.

I. Surface Stormwater Detention Facilities

DESIGN CRITERIA

1. Integrate water quality treatment techniques such as biofiltration swales and ponds with overall site design, where possible and appropriate.

INTENT

- To promote more effective integration and use of biofiltration swales and ponds in site design and landscaping.

GUIDELINES

Incorporate biofiltration swales into landscape design, where appropriate. Note that swales may be used to partially fulfill landscape requirements. The following three treatments are listed in the order of preference.

Note: Refer to the Water and Sewer Chapter of the Tukwila Municipal Code for requirements for water quality treatment of storm water, and standards for swales and other water quality devices.



Figure 18: Biofiltration swales can incorporate stormwater management in a soft, attractive, naturalistic way. At this shopping center, a drainage swale in a central open space serves as a visual amenity.

- a) (Generally, first preference where topography and other site conditions will allow.) Locate biofiltration swales, pond, or other approved biofiltration systems at the side or rear of the lot and incorporate as part of a landscape screen. Trees may be planted near the grass swale as long as they do not substantially shade the grass within the swale. Orient the swale or pond so it does not impede pedestrian circulation or shared parking between two or more properties.

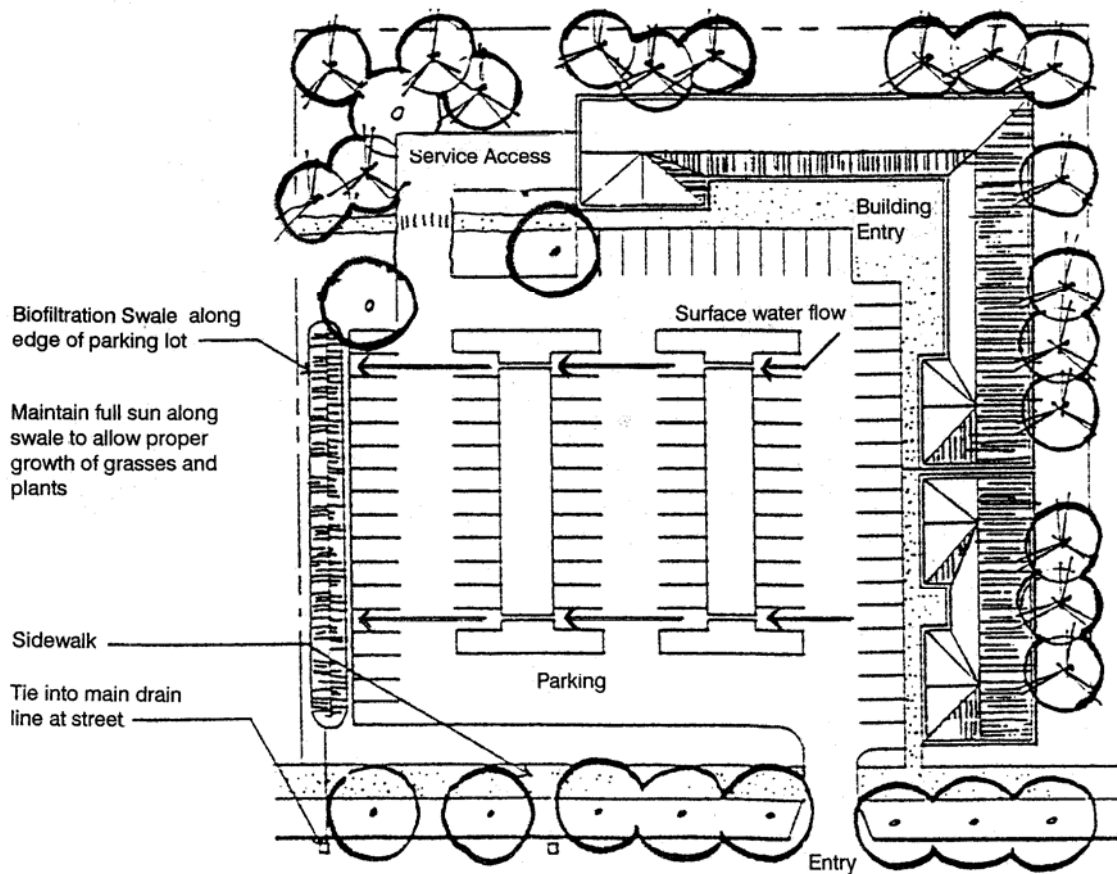

Figure 19: Biofiltration swale or pond design option (a). Biofiltration systems located at the side or rear of a parking area can drain parking lot run-off and serve as part of a landscape screen.

- b) (Generally, second preference where topography is favorable.) Locate biofiltration swale, wet pond, or other approved biofiltration system within the paved parking or service area. Orient the swale or pond so it does not impede pedestrian circulation, and landscape it as part of the required internal parking lot landscaping.

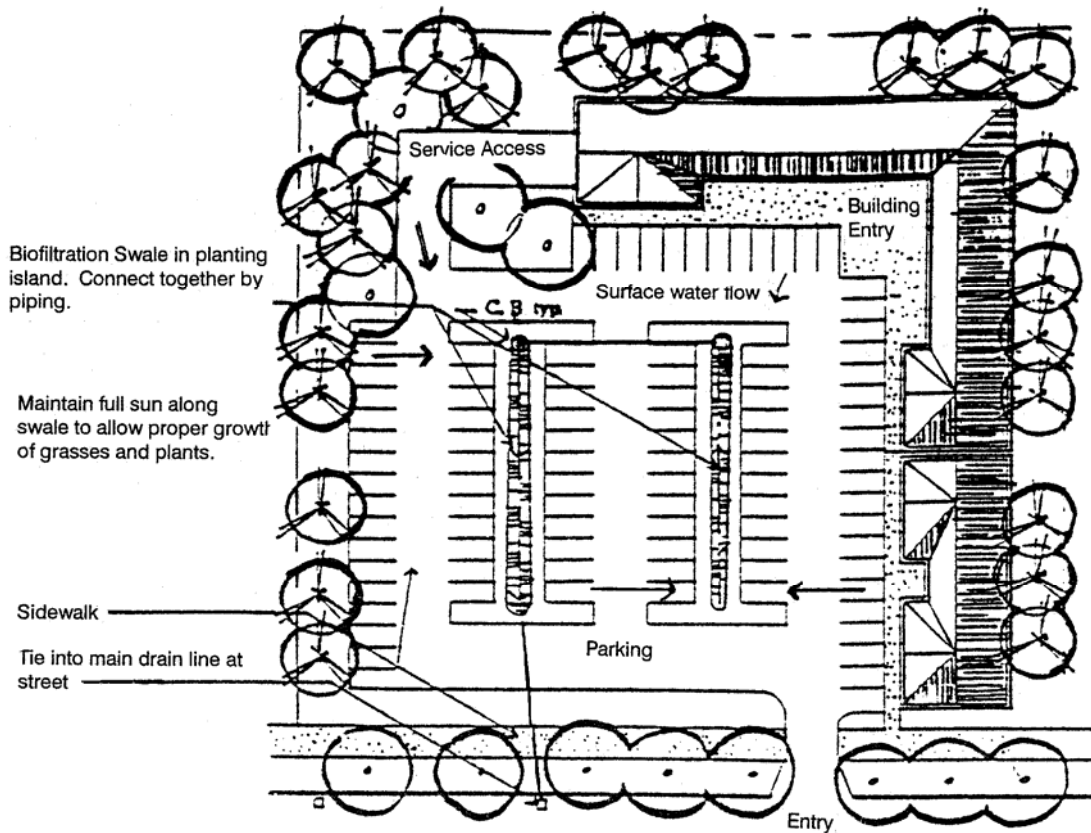

Figure 20: Biofiltration swale or pond design option (b). Biofiltration systems located within a parking area can drain parking lot run-off and enhance landscaping in the area.

- c) (Generally, employ this option only when options a and b are not practical.) Locate the swale along the front edge of the property. Incorporate landscaping to visually enhance the swale without reducing the ease of maintain. Larger biofiltration ponds should not be located along the front edge of the property.

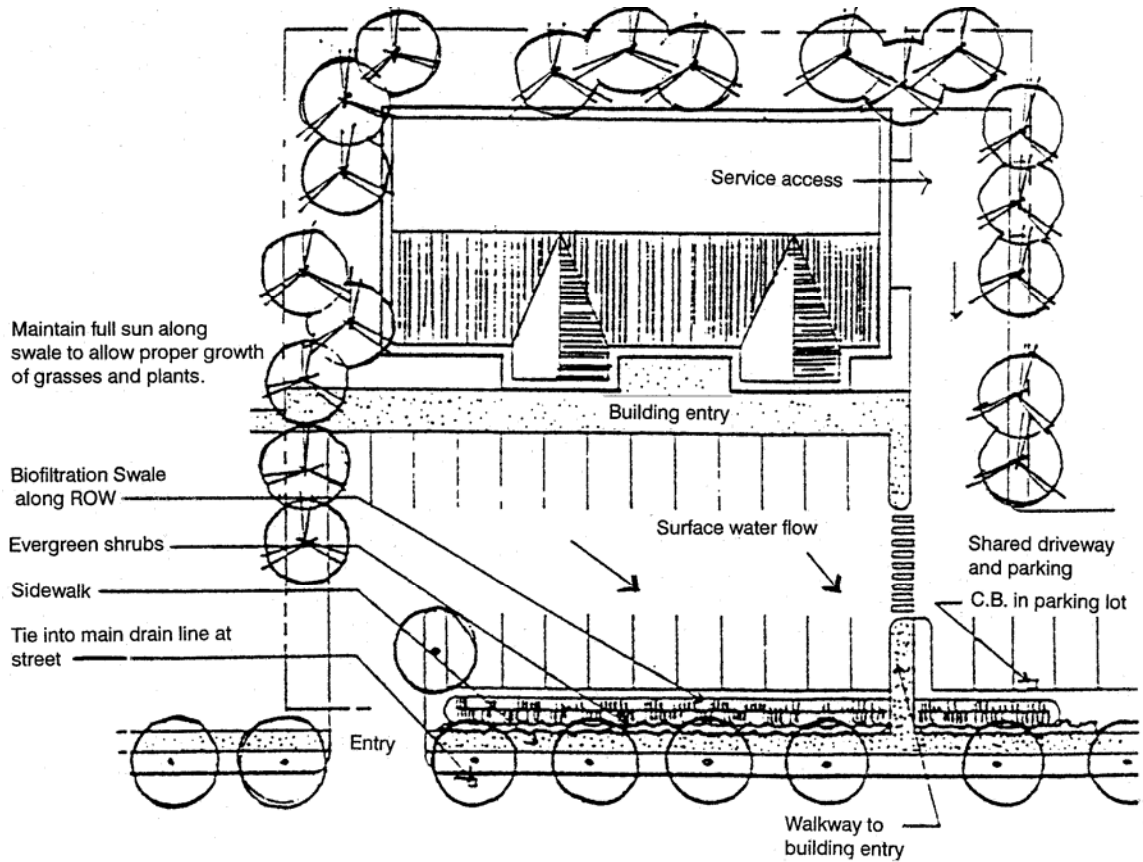

Figure 21: Biofiltration swale or pond design option (c). Biofiltration systems located along the front edge of a parking area can drain parking lot run-off and serve as part of a landscape screen.

J. Pedestrian Circulation

DESIGN CRITERIA

1. **Provide paved pedestrian walkways that connect all buildings and entries of buildings within a site.**

INTENT

- To improve the pedestrian environment, making it easier, safer and more comfortable to walk between building entries.

GUIDELINES

Provide pedestrian walkways connecting all building entrances within the site. Walkway widths should be sized to accommodate anticipated use.

Six foot sidewalks accommodate two pedestrians and should be the minimum width for walkways connecting building entrances within one structure. Additional width is encouraged.

Provide grade separation or otherwise distinctively marked pedestrian walkways and crossings from parking areas and across driveways to building entrances, where possible. See Criteria 1.F.1., “Site Design for Safety” for guidance.

Note: Sidewalks are required that connect parking areas behind buildings to building entrances. See the Zoning Code for standards.

Note: Refer to the Washington State Code governing Barrier Free Design for standards and requirements for the disabled.

DESIGN CRITERIA

2. **Provide a paved pedestrian walkway from the public sidewalk(s) to the main entry of developments.**

INTENT

- To improve the pedestrian environment, making it easier, safer and more comfortable to walk from the street to building entries.

GUIDELINES

Provide pedestrian walkways from public streets to building entries. Six foot sidewalks accommodate two pedestrians and should be the minimum width for these walkways. Walkways that extend through parking areas and across driveways should be designed in accordance with Criteria 1.F.1. in “Site Design for Safety.”

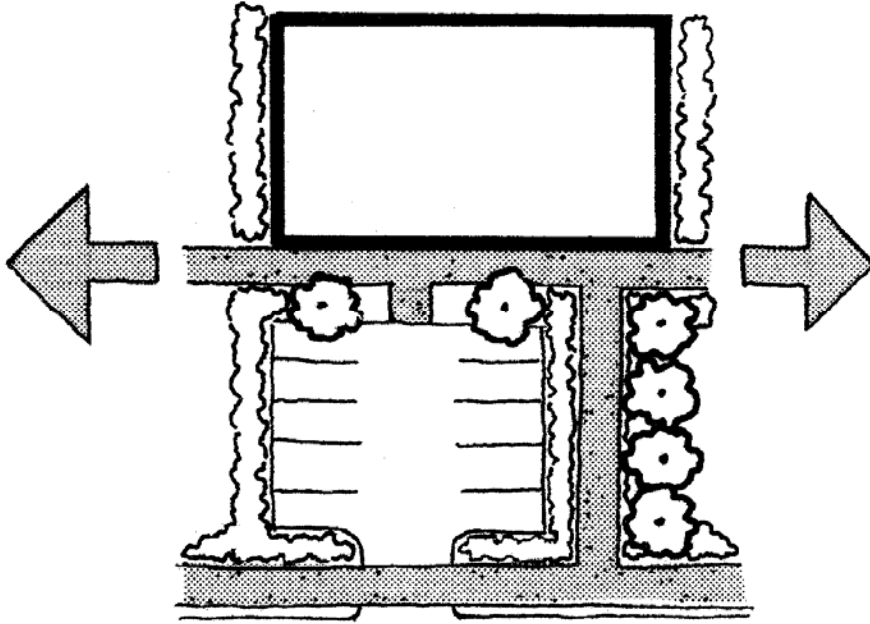

Figure 22: Landscaped walkways connect the public sidewalk with the entrance to a building set back from the street and also provide convenient access to neighboring properties, which encourages multiple-purpose trips.

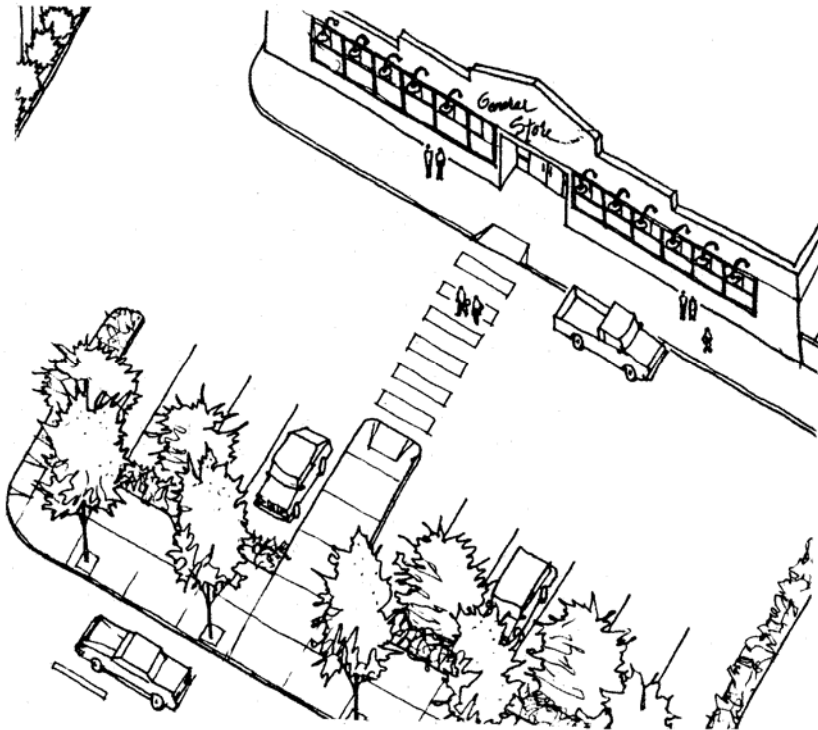

Figure 23: Provide a safe, accessible pedestrian route from the street to the building entry.

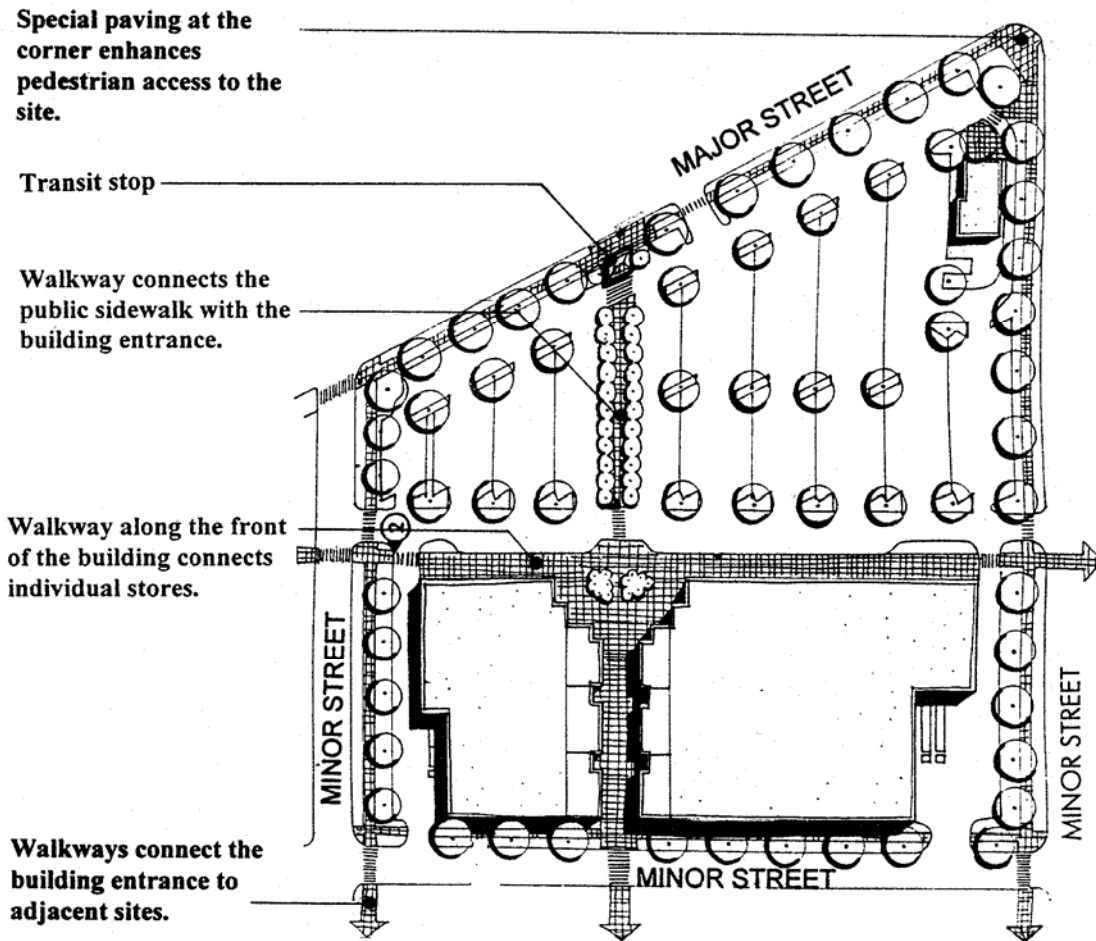

Figure 24: In this large-scale commercial site, wide, landscaped walkways provide pedestrian connections.

DESIGN CRITERIA

3. Provide pedestrian connections from the on-site pedestrian network to walkways on adjacent properties and to other off-site destinations, where feasible.

INTENT

- To provide a safe, continuous pedestrian network throughout the Tukwila International Boulevard area.
- To provide for the additional convenience of businesses and customers.
- To reduce the number of vehicle trips required for customers.

GUIDELINES

Provide connecting pedestrian links between the site and adjacent properties, when advantageous and appropriate for adjacent uses. Refer to Criteria 1.F.1, 1.F.4 and 1.F.5 in "Site Design for Safety" for additional guidance. Take into consideration the following when designing pedestrian connections:

- General off-site destinations such as commercial centers, schools and public buildings, transit stops, and residential complexes.
- Existing and planned public facilities, such as signalized intersections.
- Building entries of nearby commercial developments and residential complexes.
- Sidewalks, vehicular drives, parking areas and other circulation elements within neighboring sites.
- Safety, such as sight-lines around building corners.

DESIGN CRITERIA

- 4. Support pedestrian movement between properties and from private property to public rights-of-way by providing facilities that traverse natural or man-made barriers, where appropriate.**

INTENT

- To make businesses more accessible and convenient for residents, customers and employees.
- To provide safe and continuous pedestrian access throughout the Tukwila International Boulevard area.

GUIDELINES

Incorporate the following in site design where connections between sites are desirable:

- a) Provide gates in fences to facilitate movement between sites.
- b) Provide steps, ramps, or a combination of the two where grades prohibit easy and/or safe movement.

DESIGN CRITERIA

- 5. Provide direct pedestrian walkways from businesses in commercial areas to transit stops, and/or provide additional transit amenities, where appropriate and feasible.**

INTENT

- To provide safe routes for pedestrians and disabled persons to transit facilities.
- To improve surveillance of transit areas from neighboring businesses.
- To accommodate customers and residents of the area who use transit.

GUIDELINES

Provide access from adjoining and nearby residential and commercial properties to transit facilities where feasible, and where it meets the needs of the project applicant.

Where security problems exist, consider the following:

- a) Through-site access may be separated from the rest of the site with a fence; and/or
- b) Access may be controlled after business hours and during evenings if necessary for security reasons. Signs should be posted to indicate when hours of access are limited.

As an incentive, improvements for transit riders located within required setbacks and landscape areas will be considered in partial fulfillment of landscape requirements, in conjunction with overall design review approval.

Transit riders typically need:

- Extra space for waiting areas;
- Walkways from transit stops to building entrances; and/or
- Pedestrian amenities, such as seating, weather protection and trash receptacles.

K. Pedestrian Amenities

DESIGN CRITERIA

- 1. Incorporate pedestrian amenities in site design to increase the utility of the site and enhance the overall pedestrian environment in the corridor, where possible.**

INTENT

- To encourage and support a high level of pedestrian activity in the Tukwila International Boulevard area.
- To create and support a pleasant, comfortable, convenient environment for the pedestrian, cyclist and disabled throughout the Tukwila International Boulevard area.
- To provide a variety of pedestrian-oriented areas that are attractive to employees and shoppers.
- To improve the visual appearance of the Tukwila International Boulevard area.

GUIDELINES

Pedestrian amenities increase the utility of a site and enhance the overall pedestrian environment. This in turn increases the attraction of commercial areas for shoppers, and improves access for those not arriving by car, including walkers, cyclists and transit users. They may be beneficial for safety reasons, and contribute to pedestrian comfort and convenience.

The following should be taken into consideration in locating pedestrian amenities and services:

- Pedestrian traffic flow, and access to business entries and other destinations
- Wind, traffic, and unpleasant sun or shade conditions.
- Convenience for business customers and employees.
- Access for those with special needs, such as the elderly, children, and the disabled.
- Automobile door swings and overhangs.

Pedestrian amenities should also not be located in such a way that pedestrians are likely to walk through landscaped areas or unsafe areas to access them.

The following is a list of pedestrian amenities that may be used to meet the intent of this criteria:

- Site furnishings such as seating, tree grates, drinking fountains.
- Pedestrian weather protection, such as awnings, canopies, marquees, or building overhangs. (Note: To be effective, the coverings should not be higher than approximately 15 feet nor lower than 8 feet.)
- Attractive signage, oriented towards pedestrians (see Criteria 4.B.1., “Sign Placement.”)
- Attractive window displays, outdoor display areas, vending of food and flowers, or permanent or temporary dining near building entrances.
- Artwork, fountains, and other attractions.
- Conveniences such as public telephones, trash receptacles, mailboxes, newspaper stands.
- Decorative screen walls, murals, and other building or site features.
- Light fixtures and lighting oriented towards pedestrians and/or highlighting landscaping or building features.
- Bike racks with weather protection.
- Special paving in pedestrian oriented areas.
- Landscape features such as hanging flower baskets, planters with seasonal displays, and trellises.
- Other features that promote pedestrian activities.

Note: The following pedestrian amenities are required by these design criteria: landscaping or pedestrian-oriented space; sidewalks to and between buildings; pedestrian friendly facades on buildings; and prominent building entries that are visible from public sidewalks and parking areas. They are discussed in greater detail in Criteria 2.D., “Pedestrian Oriented Features,” and Criteria 1.J., “Pedestrian Circulation.”

L. Vehicular Circulation

DESIGN CRITERIA

- 1. Minimize conflicts between vehicular and pedestrian traffic.**

INTENT

- To provide safe, convenient vehicular access to businesses without degrading the pedestrian environment.

GUIDELINES

Incorporate one or more of the following methods to clearly distinguish between vehicle and pedestrian circulation areas:

- a) Locate vehicle driveways on the perimeter of the site, thereby limiting pedestrian crossings within the site.
- b) Provide parking adjacent to buildings.
- c) Use raised walkways, bollards, wheel stops, and landscaping to physically separate vehicles and pedestrians.
- d) Install contrasting paving materials or colors to distinguish between pedestrian and vehicle circulation areas, especially at crosswalks.
- e) Provide additional lighting at pedestrian crossings and where security is a concern.

Note: See also Criteria 1.F., “Site Design for Safety” and 1.J., “Pedestrian Circulation.”

DESIGN CRITERIA

- 2. Minimize the amount of space devoted to vehicular circulation by limiting access driveways; ensuring that internal site circulation is efficient; and/or taking advantage of opportunities for shared driveways.**

INTENT

- To promote efficient use and higher utilization of site land area.
- To eliminate redundant or duplicative facilities.
- To minimize the impact of vehicle entries on traffic flow.
- To reduce the impact of curb cuts on pedestrian walkways.

GUIDELINES

Vehicular circulation within sites and between sites can be improved through careful site planning (see Criteria 1.A.1., “Site Design Concept,”) and planning for shared facilities (see Criteria 1.E.1., “Shared Facilities.”) This in turn will increase utilization of land, ensure that parallel access roads are not provided when they are not necessary, reduce the number of pedestrian/vehicular conflicts, and improve traffic flow.

Incorporate the following methods to minimize the amount of space devoted to vehicular circulation where possible:

- a) Minimize the number of access points to the site by
 - Utilizing shared driveways and/or shared parking facilities with neighboring properties, and
 - Sharing access drives and circulation routes between customers, employees and service traffic, where possible.
- b) Limit access drive and parking aisle widths where possible.

Provide pedestrian connections between properties, thereby minimizing the number of vehicle trips required.

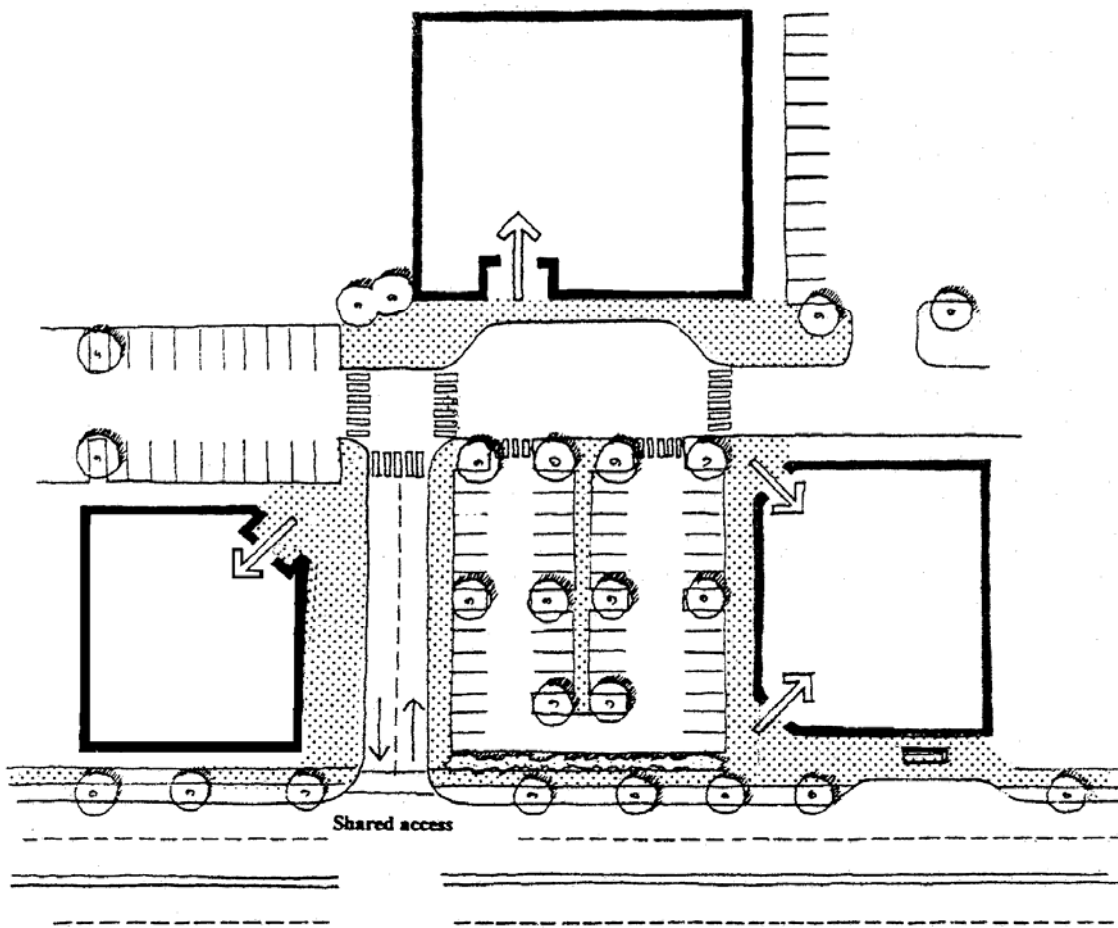

Figure 25: Shared driveways and shared parking lots can reduce parking requirements and create a more pedestrian-friendly environment by reducing curb cuts along streets.

M. Parking

DESIGN CRITERIA

1. **Minimize the amount of space devoted to parking by taking advantage of shared parking and/or methods for reducing parking demand, where possible.**

INTENT

- To minimize the visual impact of large paved areas.
- To increase site utilization by reducing the amount of land area devoted to automobile parking.
- To increase the attractiveness of Tukwila International Boulevard for pedestrians.

GUIDELINES

Incorporate the following methods to reduce the amount of space devoted to parking where possible:

- Take advantage of opportunities for shared parking with neighboring properties.

Note: The side yard landscaping requirement will be waived provided that it is approved in conjunction with overall design review approval for the portion of the side yard used for common driveways and/or parking and that it occurs between adjoining commercially zoned sites.

- Provide two or more small parking areas rather than one large parking area, particularly if one parking area occurs between the building and the street.
- Provide pedestrian connections between properties, thereby minimizing vehicular travel by customers.
- Provide pedestrian connections to transit, where possible, to reduce parking demand for employees and customers.
- Provide bike racks in convenient and safe locations, with weather and security protection where possible.

Note: See parking section of the Zoning Code for procedures for establishing shared parking.

2. Building Design

A. Architectural Concepts

DESIGN CRITERIA

1. **Develop an architectural concept for structure(s) on the site that conveys a cohesive and consistent thematic or stylistic statement, and is responsive to the functional characteristics of the development.**

INTENT

- To encourage building design in which the organization is easily understood, is appropriate to the site, and that is a positive element in the architectural character of the Tukwila International Boulevard area.
- To encourage consideration of how the various building pieces are brought together without prescribing a specific architectural style. (Note: Other building design guidelines in this Manual address specific building elements and aspects of building form and organization.)

GUIDELINES

The architectural design of a proposed project must demonstrate a strong unifying concept, clear organization, and a consistent architectural character or style.

The architectural forms, elements and details of a project should be organized to clearly express the building's function(s), orientation, and relationship to the site and surrounding area. In addition to conveying this organizational information, a strong architectural concept will communicate a distinctive architectural character or style.

The following examples illustrate ways in which architectural forms, elements and details may be organized to convey a strong architectural concept.

Building Composition. The composition of a building's larger masses and elements can create a unifying concept. The two types of composition (or design) illustrated below are symmetry and asymmetry. Building forms and facades may also be organized around an axis or approach, in a linear fashion, or on a grid. There are many types of organization; the importance of the organization is that it is clear, appropriate to the building's function, and its context.

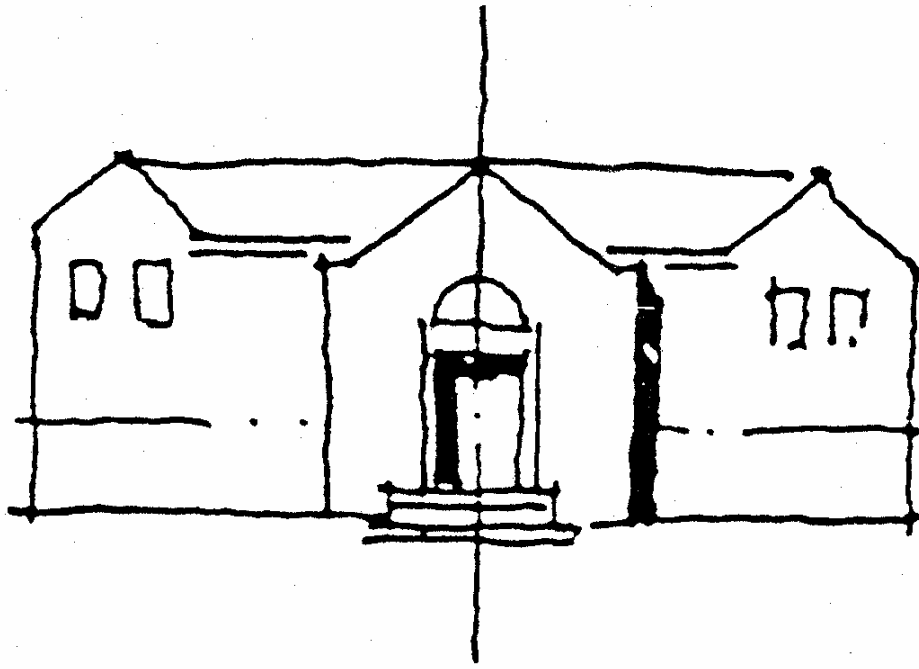

Figure 26: Axial Symmetry is a formal design organization in which the building elements on one side on the centerline axis are the same as on the other side.



Figure 27: Asymmetry is an informal composition in which larger design elements are often visually balanced by a number of smaller elements within the composition.

Organization in relationship to an exterior space is another approach to establishing a strong architectural concept. For example, buildings may be oriented around a courtyard, be terraced down a hillside, or respond in design to a prominent corner location.

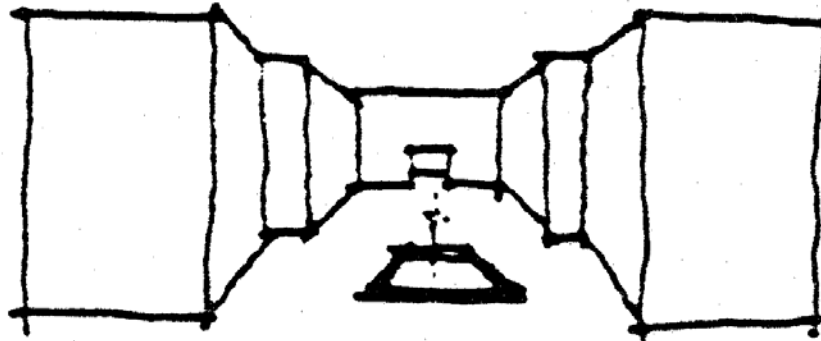

Figure 28: Organization Around a Central Exterior Space, such as a courtyard or garden, is an effective way to organize a site for some uses, and create an amenity.

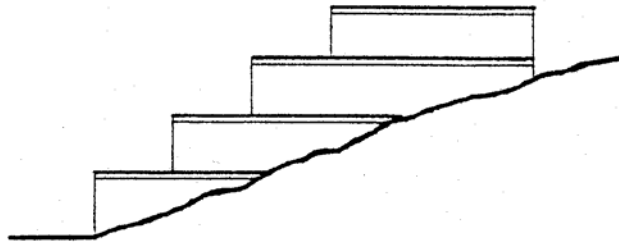

Figure 29: Terracing, dividing a building into horizontal terraces that step down a steep slope is a way to respond appropriately to site conditions. This organization can also provide usable decks.

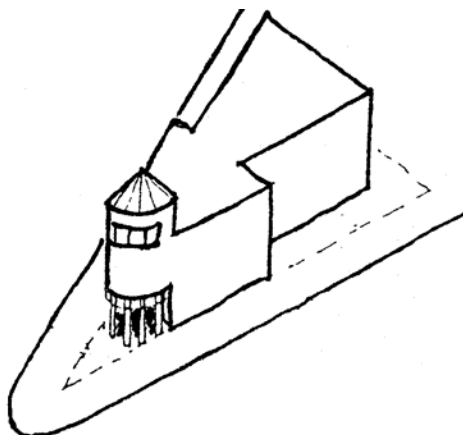

Figure 30: Taking Advantage of Visibility. Responding to an unusual site condition, such as a highly visible corner, is another way to create a distinctive and appropriate design concept.

Building Elements such as distinctive roof forms, entrances, an arcade or porch, or the arrangement of doors and windows can provide for compositional unity and convey a strong architectural concept.

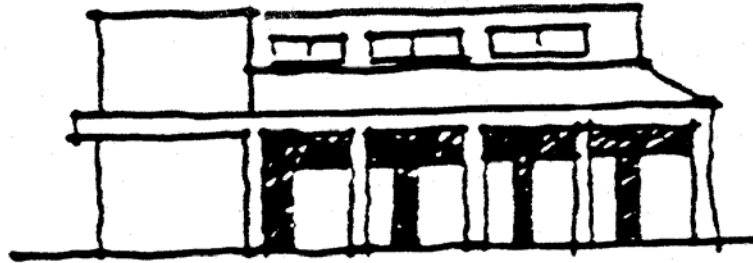

Figure 31: *Inclusion of a Major Architectural Feature, such as a turret, portico, or arcade, can provide a strong focus or unifying element in building design.*

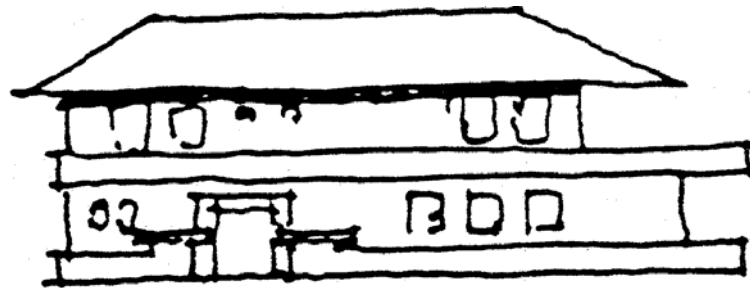

Figure 32: *Distinctive Horizontal Banding, can unify the disparate elements in a building facade, or establish more human scale in tall structures*

Building Details, such as moldings, mullions, rooftop features, and materials can display a distinctive architectural style, contributing to a strong architectural concept.

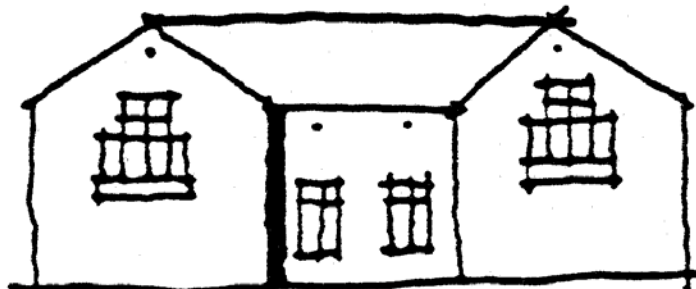

Figure 33: *Unusual or distinctive detailing can unify a design and lend scale and character.*

DESIGN CRITERIA

- 2. Ensure that development on sites with more than one structure employ similar or complementary architectural styles and/or are related in scale, form, color, and use of materials and/or detailing.**

INTENT

- To encourage the development of a strong architectural concept on sites with multiple buildings.
- To encourage a unified appearance in large lot developments.

GUIDELINE

Projects with multiple structures are required to display a unifying concept, or incorporate design elements or features that relate the structures to one another. This may be expressed in the building forms or stylistic devices such as architectural style, color, materials and/or detailing.

B. Architectural Relationships

DESIGN CRITERIA

- 1. Provide for visual and functional continuity between the proposed development and adjacent and neighboring structures when these structures demonstrate an appropriate level of architectural quality.**

INTENT

- To reinforce the positive visual qualities of the Tukwila International Boulevard corridor.
- To ensure that new development is in keeping with the existing architectural context, when neighboring structures provide positive examples.
- To support the development of a new architectural context in the Tukwila International Boulevard area, where appropriate.

GUIDELINES

The Tukwila International Boulevard area currently features buildings of varying architectural character, styles, and quality. The general architectural context of Tukwila International Boulevard consists of horizontally oriented structures placed relatively close to the street. This should be continued where appropriate; that is, where it fulfills the goals expressed in the Comprehensive Plan, Zoning Code, and this Design Manual.

Where new building forms and placement are encouraged, that is, as identified in the Comprehensive Plan, Zoning Code, and this Design Manual, a new architectural context must be established over time. Once positive new examples or a desirable architectural context is established, new structures can be designed to ‘fit in’ through careful attention to placement on the site, building form and massing, scale, roof form, the proportions and arrangement of openings (windows, doors, entries, arcades), architectural elements, materials, colors, and decorative details.

Projects are expected to exhibit a high degree of design quality that can be emulated in the future. Development proposals will generally be considered on a site-by-site basis for compatibility with the existing and planned built environment.

The following illustrations demonstrate how the use of appropriate building forms and elements can provide continuity in an architectural setting.

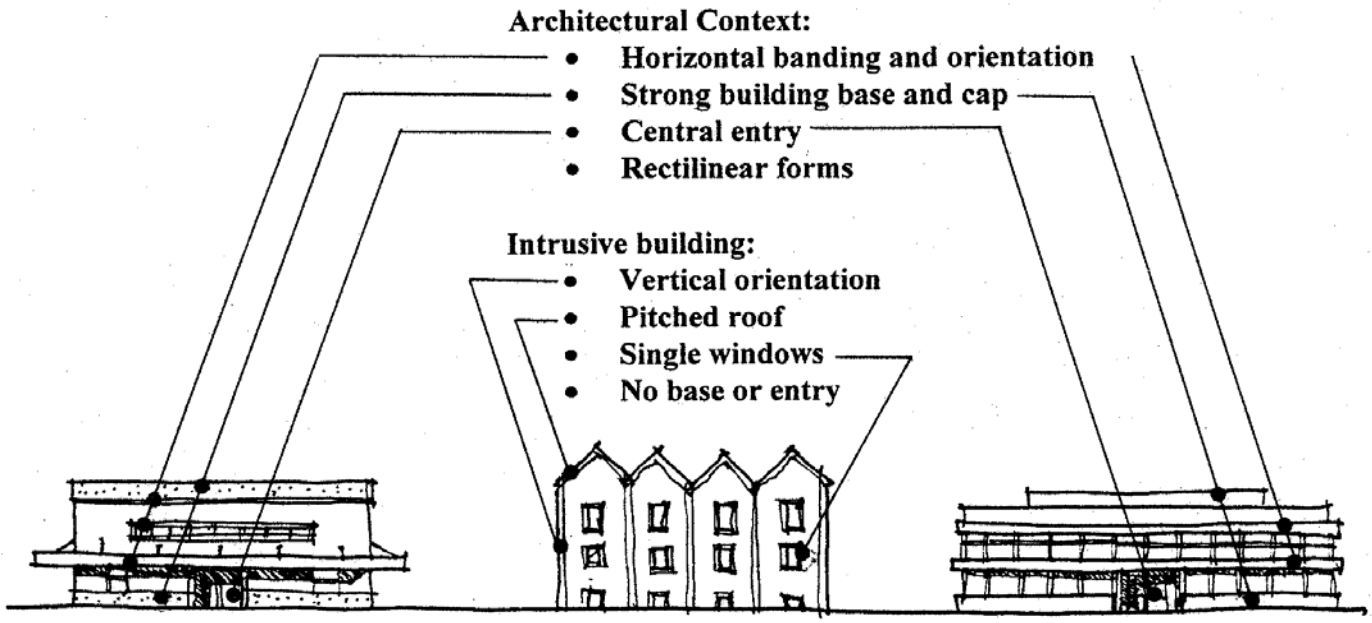

In this example, the middle building does not fit with the architectural context set by its neighbors.

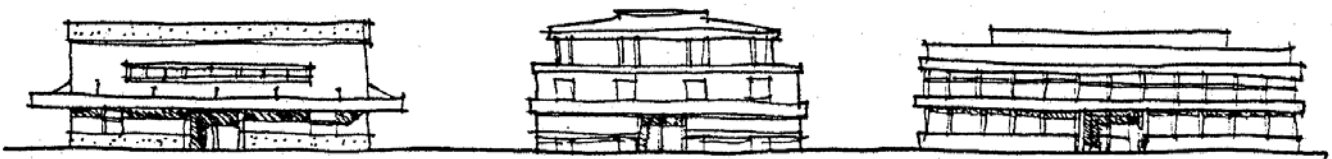

In this example, the middle building better fits its architectural context because the horizontal banding, cap and base and central entry relate to neighboring buildings.

Figure 34: Where a context has been established, and is appropriate, new structures can be designed to "fit in."



Figure 35: The pattern and proportion of windows, doors, and other openings are important in establishing a building's architectural character. If the proportion and pattern of neighboring buildings' fenestration is followed, consistency within an established architectural context will be increased.

DESIGN CRITERIA

2. **Reduce the apparent scale of large commercial buildings located in the Neighborhood Commercial Center district and those located adjacent to residential districts.**

INTENT

- To promote an architectural scale that is conducive to establishing a neighborhood commercial district focused around the intersection of Tukwila International Boulevard and S. 144th St.
- To encourage new development to incorporate design features that establish a scale compatible with the surrounding residential community.

GUIDELINES

Buildings in the NCC zone and buildings in the RC zone located adjacent to residential zones, and over 100 feet in length (as measured along any facade), must employ one or more of the following measures to reduce apparent building mass:

- a) **Modulation:** Building modulation is the stepping out or in of a particular portion of the facade. The stepped-out portions must be at least 4 feet deep in order to qualify as modulation.

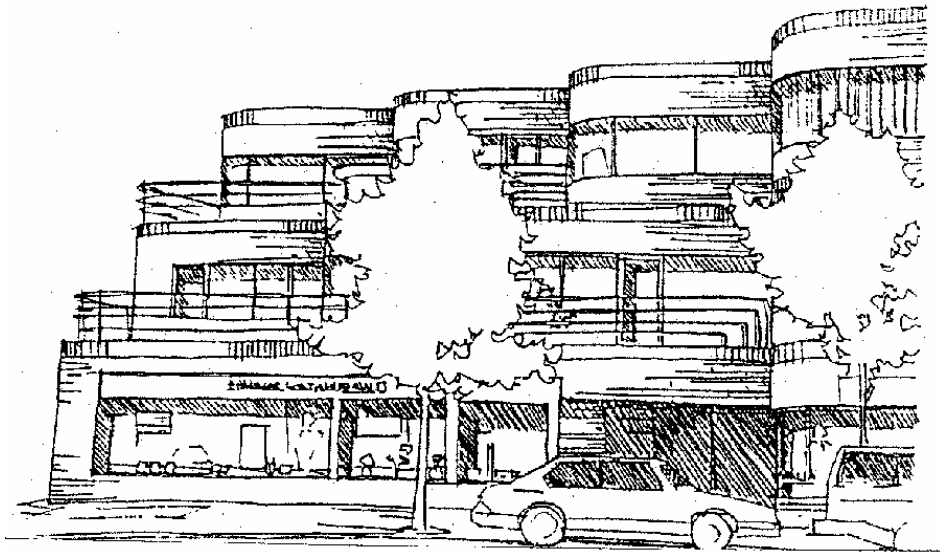

Figure 36: *Setting back upper stories helps to reduce the apparent bulk of a building and promotes human scale.*

- b) **Distinctive Roofline:** A distinctive roof line (particularly a sloped roof) can reduce perceived building height and mass, increase compatibility with smaller scale and/or residential development, and add interest to the skyline (See illustrations page 57)

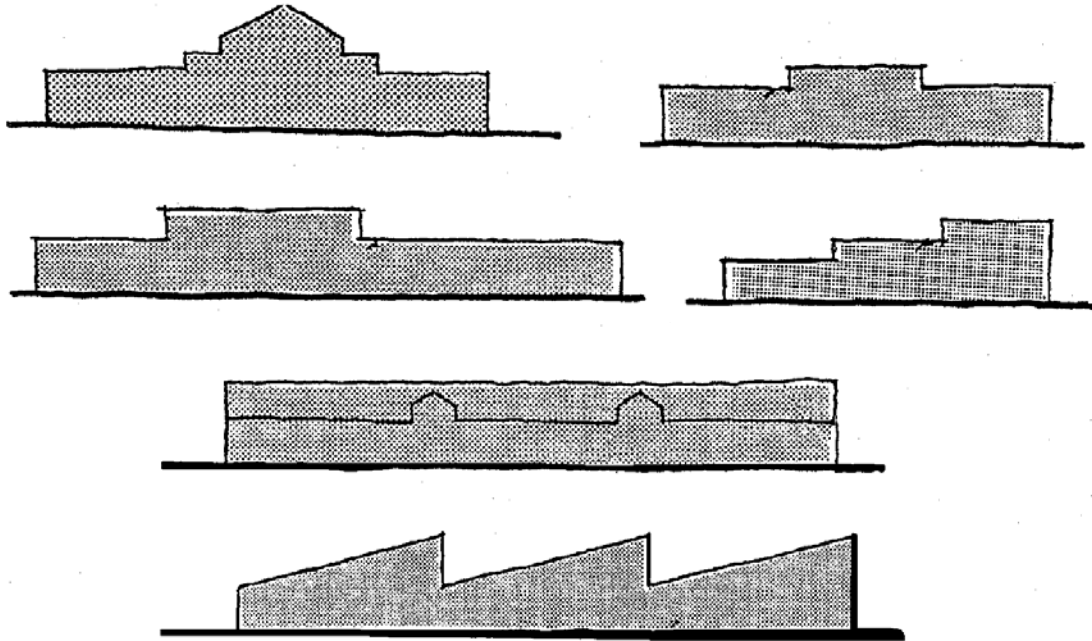

Figure 37: Roofline variations add interest to simple building forms and help reduce perceived mass.

- c) Small Scale Additions: Small scale additions to a structure can reduce apparent bulk by articulating the overall form or massing. Clustering smaller uses and activities around entrances on street-facing facades also allows for small retail or display spaces that are inviting and add activity to the streetscape (see illustration below).

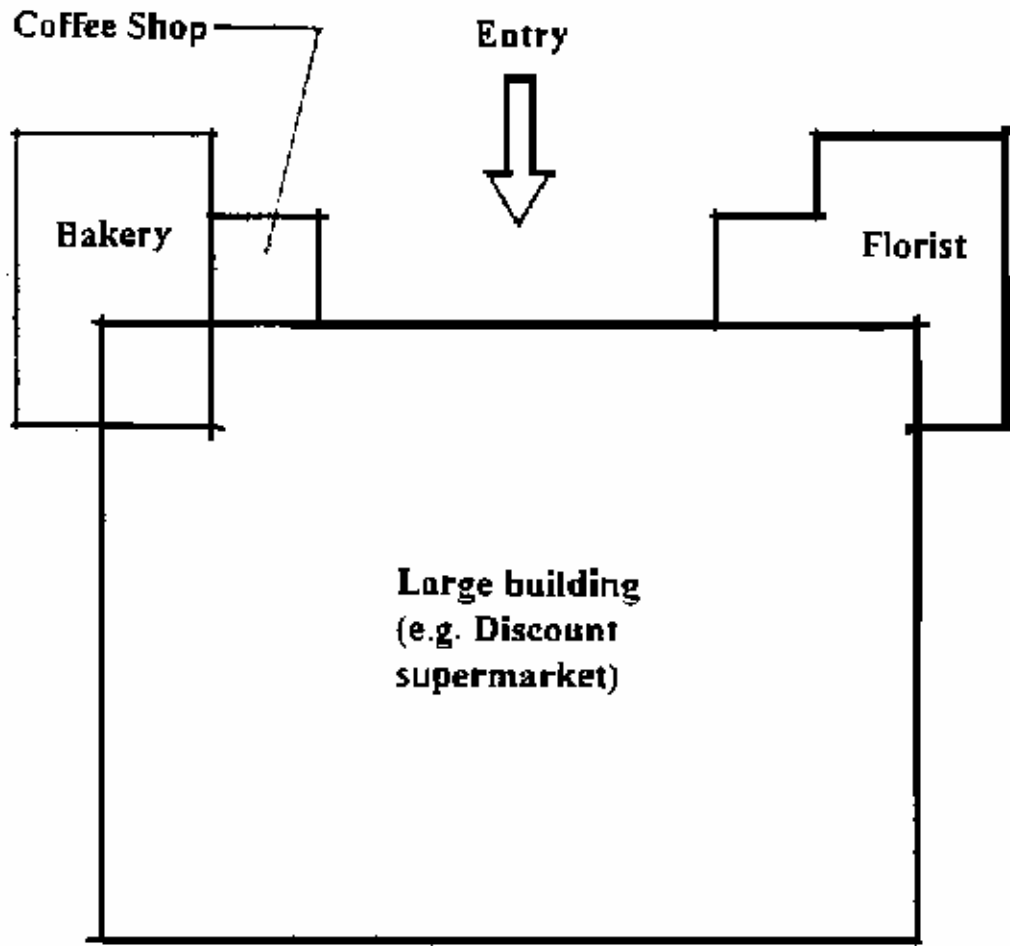

Figure 38: Clustering smaller activities around the entrance to a large building adds human scale and minimizes the large building bulk.

- f) Special Building Features: The mass of long or large scale building can be made more visually interesting by incorporating architectural elements such as arcades, balconies, bay windows, dormers and columns.



Figure 39: The roofline, windows, and details of this building break up the facade of an otherwise horizontal building. Note how the awnings and lights provide human scale while their repetition relates back to the building massing.

- d) **Articulation:** Strong vertical and horizontal reveals, off-sets, and three-dimensional detail can be incorporated into building design to create shadow lines and break up the flat surfaces of a facade. Articulation can also be achieved through a change of materials, color and/or texture.

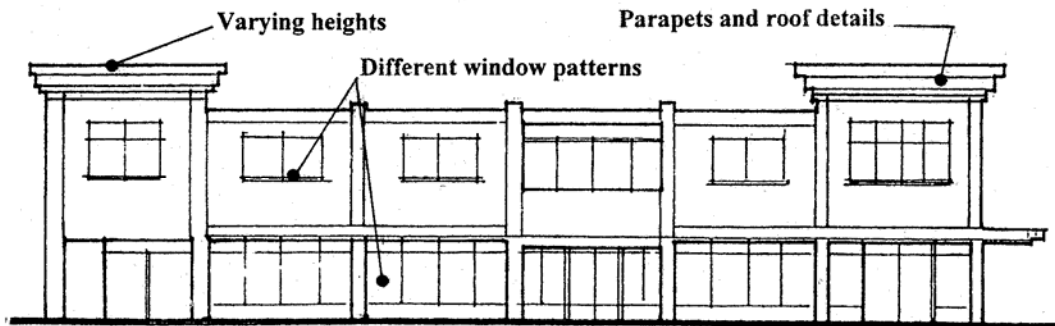

Figure 40: Buildings can be articulated in several ways.

- f) **Landscaping:** Landscaping can also reduce the apparent scale of a building, and create visual interest along a facade. Regularly spaced trees or large shrubs break up the building plane into smaller areas, and help relate the size of the structure to that of a person.
- g) **Other Methods:** Other methods that meet the intent of this criteria may be proposed.

C. Building Elements, Details, and Materials

DESIGN CRITERIA

- 1. Provide distinctive building corners at street intersections through the use of special architectural elements and detailing, and pedestrian-oriented features where possible (see Appendix A, Definitions, for “pedestrian friendly facade.”)**

INTENT

- To ensure that buildings take advantage of these prominent locations by incorporating unique, distinctive architectural features.
- To emphasize important intersections along Tukwila International Boulevard.
- To add visually interesting, identifiable elements to the streetscape.

GUIDELINES

Buildings at intersections are highly visible and present an opportunity for distinctive or landmark architectural treatments. Take advantage of these locations by employing one or more of the following:

- a) Project, recess (‘notch’) or truncate the corner of the building.
- b) Provide a building entrance at the corner.
- c) Create architectural emphasis with a roof deck, balcony, or penthouse on the upper story.
- d) Provide a corner architectural element such as a bay window, turret or pediment.
- e) Employ distinctive signage at this location.
- f) Incorporate sculpture, other artwork or a distinctive use of materials.
- g) Create a special window treatment, awning, or canopy.
- h) Other methods that meet the intent of this criteria may be proposed.

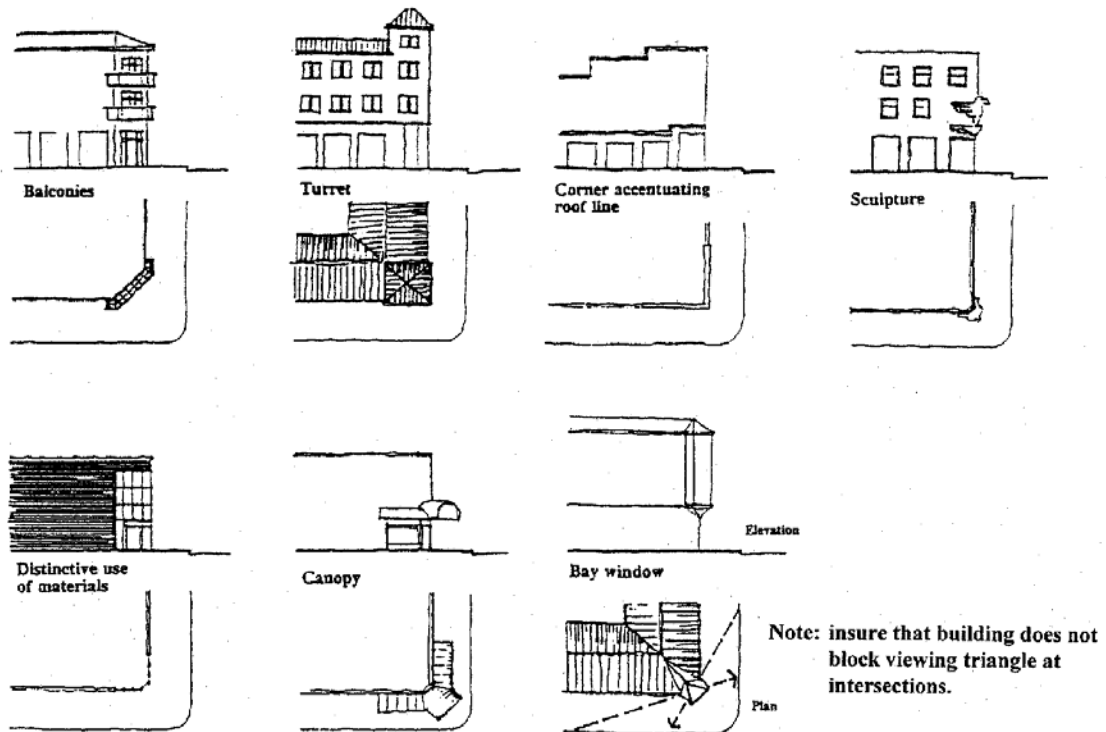

Figure 41: Examples of special corner treatment.

DESIGN CRITERIA

2. **Relate the design and scale of building elements and details to the building's overall form and massing.**

INTENT

- To provide a clear, understandable relationship between the overall massing of the building and its architectural elements and details.
- To employ architectural elements and details that reduce the apparent scale of a building, where this is desirable (see also Criteria 2.B.2., "Architectural Relationships.")
- To provide for 'human scale' in building design.

GUIDELINES

The architectural 'parts' of a building must be related to the 'whole.' Appropriately scaled and well-proportioned architectural elements such as roof forms, entrances, arcades, porches, columns, dormers, doors and windows reduce the apparent scale of a structure, and help relate the scale of a building to its user. Good proportions and relationships in building elements and details are also valuable because they are visually pleasing, and can impart a sense of well-being in the observer.

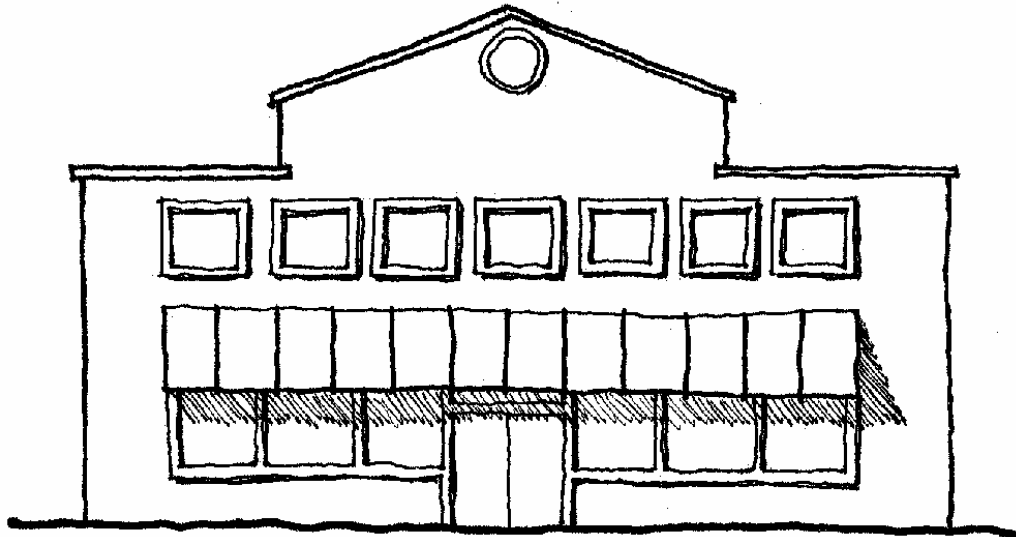
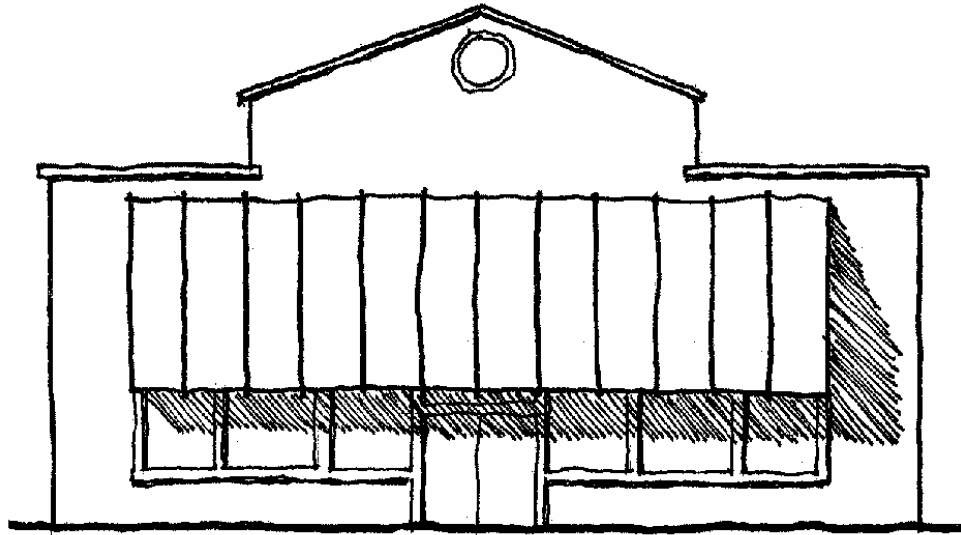

Figure 42: The top building's awning is too large both for its intended function and for the scale of the building. The awning on the bottom building is appropriate to the building's form and scale.

Project proposals must demonstrate that the elements of a building are related in scale, proportion and placement to the overall building form. Architectural details must also be related in scale, proportion and placement to the building's architectural elements or features. One way to accomplish this is to consider the building's basic structural elements as creating a set of dimensional modules that proportionally tie the various elements together. (See illustration below).

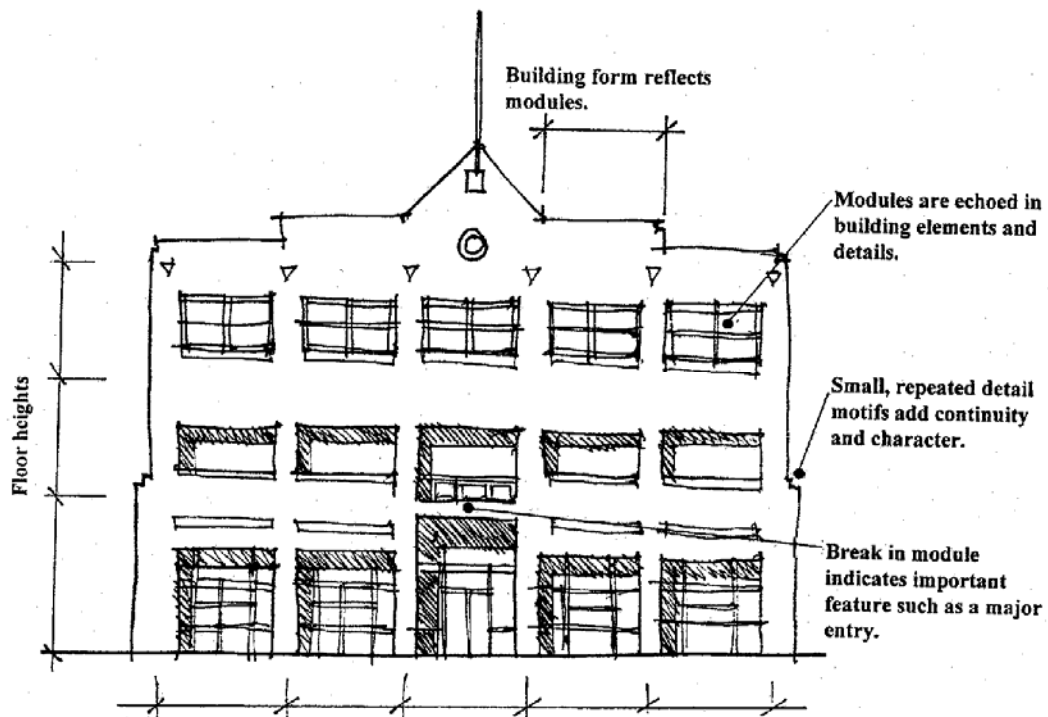

Figure 43: Building divided into modules, to facilitate related the buildings 'parts' to the 'whole.'

Note: See Criteria 2.B.2., “Architectural Relationships” for additional ways to relate the various ‘parts’ of a building to the ‘whole.’

DESIGN CRITERIA

3. **Employ architectural details that are appropriate to the architectural character of the building.**

INTENT

- To promote building design in which details are proportionate and consistent in character with the structure and/or development.

GUIDELINES

Appropriate architectural details are just as important as architectural elements in conveying the purpose and character of a building. For example, finely wrought moldings would be out-of-place on a aggregate finish, concrete building panel. Similarly, a metal industrial door would be inappropriate as an entry to a traditional, wood-frame retail storefront.

Building details, from doors, windows and spandrel panels to moldings, mullions, coping, reveals, and other decorative features, must be consistent in style and compatible in material, color and texture with the other details of the building.

DESIGN CRITERIA

- 4. Utilize durable, high quality building materials that contribute to the overall appearance, ease of maintenance, and longevity of the building.**

INTENT

- To upgrade the visual appearance of the Tukwila International Boulevard corridor.
- To minimize maintenance needs and discourage vandalism.

GUIDELINES

The selection and use of exterior building materials is a key factor in determining how a building will look. Building materials contribute pattern, scale, color and texture to a structure, and become an important design feature when well used.

Some materials, by their nature, impart a sense of permanence. Others are associated with impermanence, or are inappropriate for certain sites or uses due to their tendency to weather, invite misuse, or convey an appearance of neglect. Building materials should be selected for ease of maintenance, and have the same anticipated life-span as the structure.

Examples of common contemporary finishing materials in commercial structures are brick, split-face block, scored or molded wood siding, and stucco-finished dryvit. Other exterior finish materials may be appropriate as well, provided they are well detailed and finished (see also Criteria 2.C.3., "Building Elements, Details and Materials.") Industrial materials such as concrete masonry block and metal siding should be detailed so that the installation exhibits a high degree of workmanship and durability. Stucco and synthetic building materials should be detailed to avoid damage due to weather or use.

Some materials, such as mirrored glass, plywood, and corrugated fiberglass, are generally impermanent and/or detract from building design. They are generally discouraged in visible locations.

DESIGN CRITERIA

5. **Integrate the design and placement of exterior lighting with the architectural design and materials.**

INTENT

- To employ lighting as a positive feature that contributes to the overall design of the building.

GUIDELINES

Select architectural lighting fixtures that complement the architectural character of a project, or that are understated in design. Alternatively, locate fixtures so that they are hidden from view. Lighting fixtures should also be compatible in design and placement with site lighting and landscape features.

Incorporate lighting design that enhances dramatic or interesting landscape or architectural features, where appropriate, with consideration for both daytime and nighttime viewing.

Illumination levels of at least two (2) foot candles at the surface of the ground must be provided in pedestrian areas and entries.

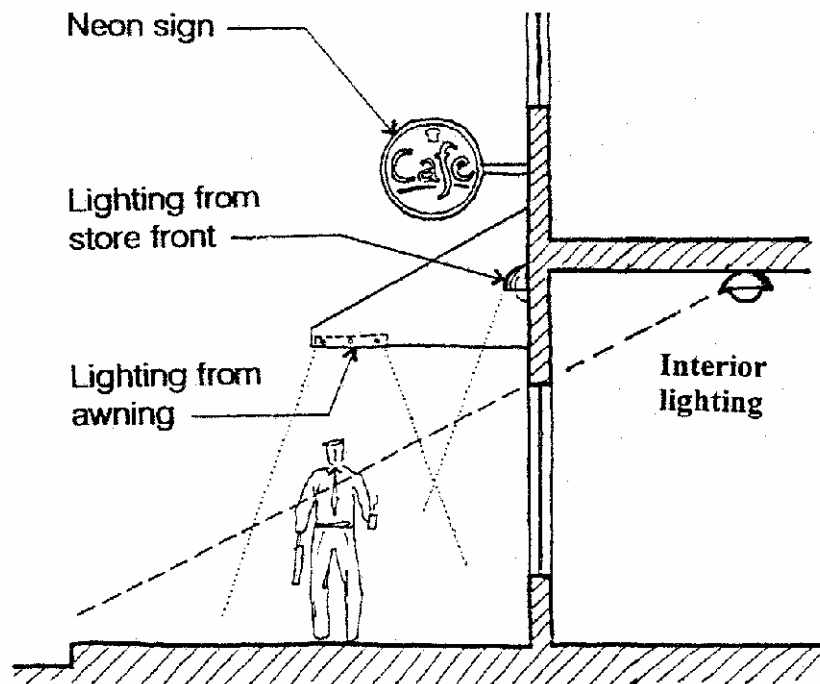

Figure 44: A combination of light sources can be desirable.

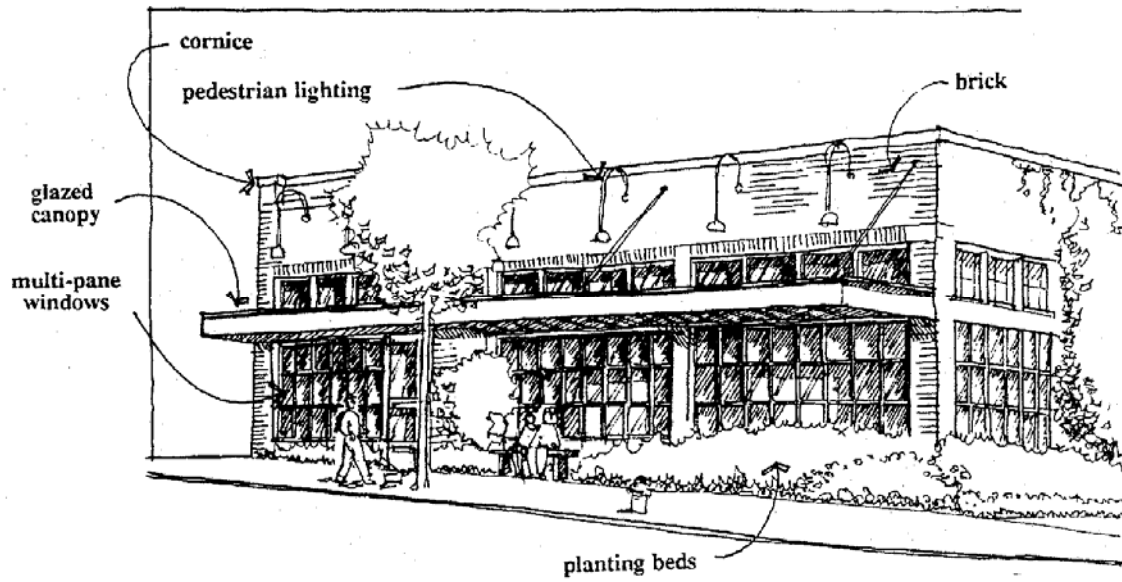

Figure 45: An example of innovative and effective lighting. The gooseneck lights, which fit the building's architectural character, shine through a glass canopy to light building surfaces and landscaping, making the building safe at night.

D. Pedestrian-Oriented Features

DESIGN CRITERIA

1. Provide pedestrian-friendly facades (see Appendix A, Definitions) on the ground floor of all buildings that face public streets and entry facades that face parking areas.

INTENT

- To make walking to and among businesses along Tukwila International Boulevard a positive experience.
- To encourage a successful "downtown" or neighborhood commercial district along Tukwila International Boulevard, and support an active street life.
- To encourage attractive and interactive facades that create visual interest.

GUIDELINES

Building facades that face public streets and entry facades that face parking areas must incorporate one or more of the following measures on the ground floor:

- a) Transparent window areas or window displays along at least half the length of the length of the ground floor facade (windows need not be contiguous).
- b) Sculptural, mosaic or bas-relief artwork along at least half the length of the ground floor facade (artwork need not be contiguous).
- c) "*Pedestrian-oriented space*," as defined in the Definitions, located adjacent or connected to the sidewalk. At least 500 square feet of pedestrian-oriented space must be provided for every 100 linear feet of ground floor facade, as visible from the public street, in order to fulfill the intent of this Criteria.
- d) Other methods that meet the intent of this criteria may be proposed.

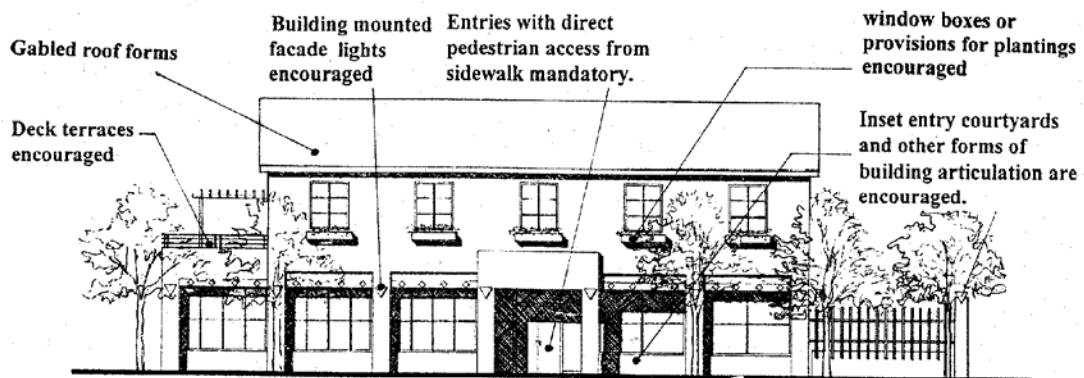

Figure 46: Examples of ways to incorporate pedestrian-friendly building details.

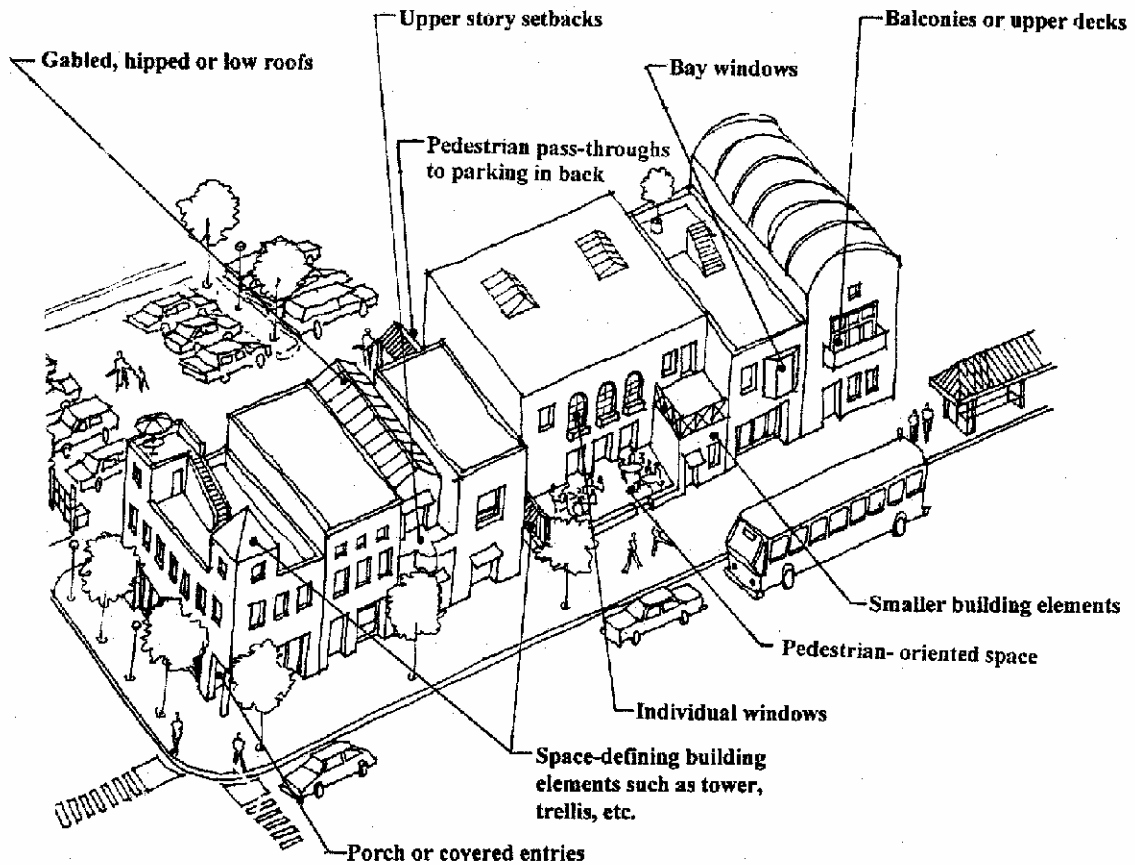

Figure 47: A sense of human scale can be achieved with building elements that indicate or promote human activities or that are defined by human use.

DESIGN CRITERIA

2. **Provide special treatment for large blank walls (see Appendix A, Definitions) that are visible from pedestrian walkways and parking areas.**

INTENT

- To reduce the negative visual impact of large, undifferentiated exterior building walls that face public areas.
- To achieve an attractive, engaging commercial district for people to walk and do business.

GUIDELINES

Incorporate one or more of the following methods to soften the appearance of blank walls that face pedestrian walkways and parking areas:

- a) Install a vertical trellis in front of the wall with climbing vines or plant materials.

- b) Provide a planting bed, berm, or raised planter in front of the wall and establish plant materials that will obscure or screen a significant portion of the wall's surface within three years.
- c) Provide artwork (a mosaic, mural, sculptural relief, etc.) over a significant portion of the blank wall surface.
- d) Incorporate a change of materials or texture in the wall and/or accent with architectural details (see Criteria 2.C.3., “Building Elements, Details and Materials.”)
- e) Other methods that meet the intent of this criteria may be proposed.

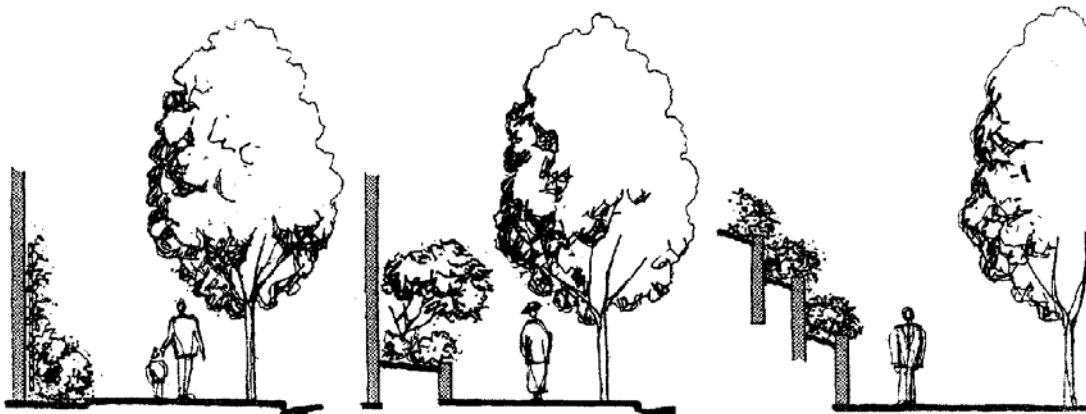

Figure 48: Blank walls can be softened and provide interest and human scale in several ways. This shows use of landscaping for visual relief.

DESIGN CRITERIA

- 3. Enhance building entries through the use of weather protection, landscaping, pedestrian amenities and/or distinctive architectural features.**

INTENT

- To provide an inviting, interesting, easily identifiable, and convenient entry.
- To enhance the pedestrian environment for customers and employees.

GUIDELINES

Incorporate one or more of the following methods to create distinctive building entries:

- a) Weather protection such as an awning, canopy, recessed entry, or other building element to create a covered pedestrian space.
- b) Landscaping (at least 100 square feet) at or near the entry.

- c) Pedestrian amenities such as benches, kiosks, special paving, bicycle racks, etc.
- d) Trellises, planters or other features that incorporate landscaping.
- e) Special lighting.
- f) Prominent window displays.
- g) Decorative elements such as mosaic tile, relief sculpture, ornamental wood or metal trim, near the door.
- h) Artwork such as sculpture, murals, mosaics or bas-relief.
- i) Special pedestrian scaled signs.
- j) Other methods that meet the intent of this criteria may be proposed.

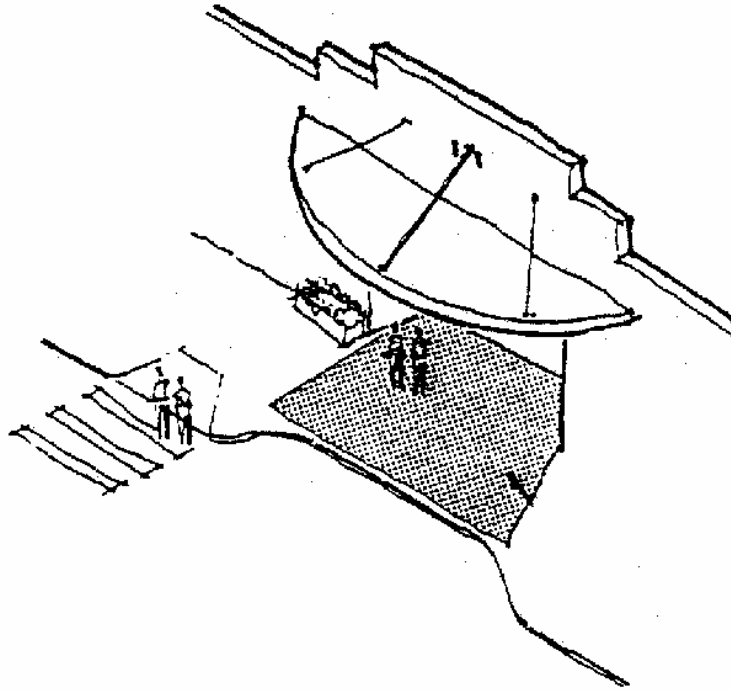

Figure 49: A covered pedestrian open space adjacent to each entry of commercial buildings is an important amenity for both shop owners and patrons.

E. Mechanical Equipment

DESIGN CRITERIA

1. **Locate and/or screen roof-mounted mechanical equipment to minimize visibility from public streets, building approaches, and adjacent properties.**

INTENT

- To reduce the negative visual and aural impact of mechanical equipment.

GUIDELINES

Screen roof-mounted mechanical equipment, including HVAC, antennas, satellite dishes, air vents, and exhaust fans, using one or more of the following methods:

- a) Design the building so that it encloses or surrounds the equipment as an integral part of the building form;
- b) Design screens for the equipment that are compatible with the architectural style of the structure;
- c) Set mechanical equipment back from the parapet so that it is not visible from public rights-of-way, major pedestrian areas, and parking areas. The diagram below illustrates the options.

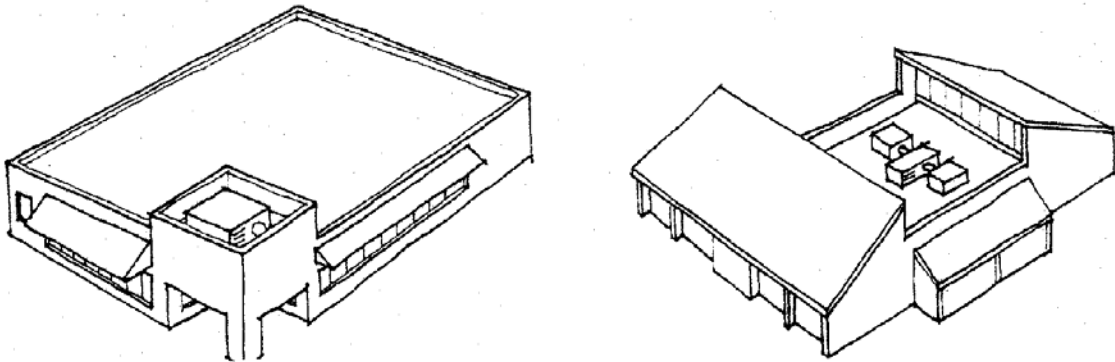

Figure 50: Mechanical equipment and service areas should be screened from view.

DESIGN CRITERIA

2. **Locate and/or screen utility meters and other ground level utility equipment to minimize visibility from the street.**

INTENT

- To reduce the negative visual and aural impact of utilities.

GUIDELINES

Enclose, paint or screen utility boxes, meters, conduit and other elements so they appear to be an integral part of the buildings, incorporate them into landscape elements, or screen them with plant materials.

Locate utility boxes so that they can be maintained or serviced without damage to the landscaping. Narrow pathways, or workpads may be installed where necessary to provide access.

3. Landscape Design

A. Landscape Design

DESIGN CRITERIA

1. **Develop a landscape design concept that demonstrates a clear and appropriate aesthetic statement.**

INTENT

- To ensure that private landscaping reinforces, complements and enhances public streetscape improvements.
- To ensure that landscape design is integrated with site and building design in a cohesive manner.
- To reinforce the positive visual elements of the Tukwila International Boulevard area.

GUIDELINES

Develop a landscape design concept that is consistent with or complementary to site design and the development's architectural character. The landscape concept should also enhance natural site features, significant existing landscaping, and/ or other existing amenities, where appropriate. An effective landscape plan will direct and enhance the experience of a site when it:

- a) Takes advantage of views of the landscaping from inside the building.
- b) Enhances the building itself, as viewed from within the site and adjacent public streets.
- c) Organizes, enhances and links the different spaces and activities on the site.
- d) Reinforces the streetscape design, and provides a pleasant transition from the street to the development.

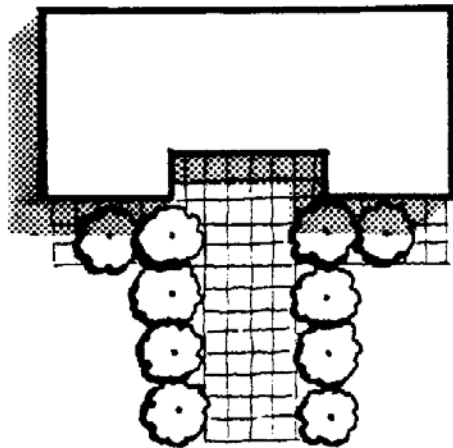

Axial symmetry along a path to enhance a building entry

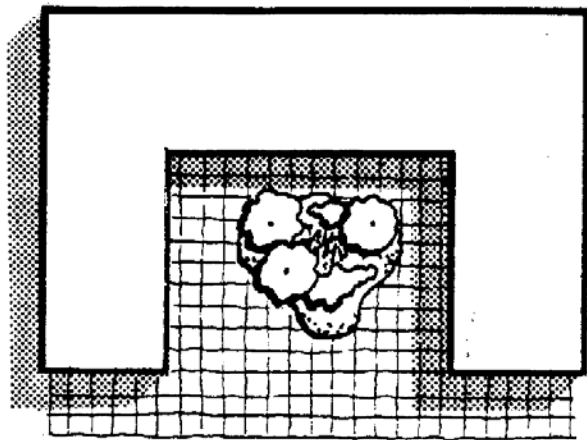

Informal landscape island to soften open space

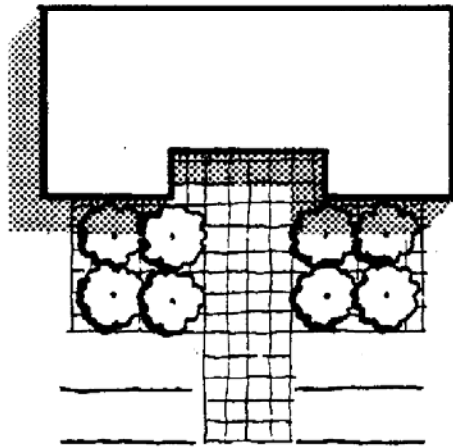

Bosc of trees to separate parking or service yard from building

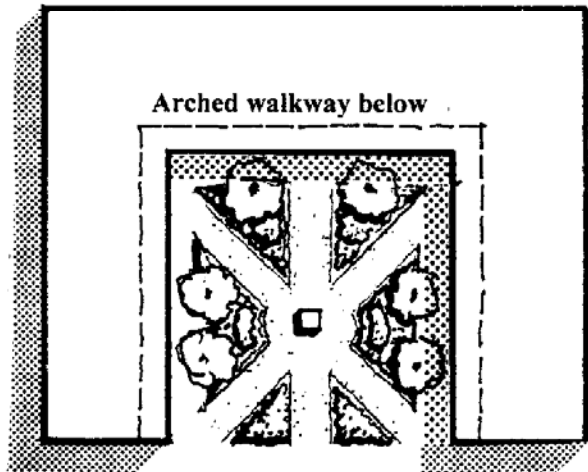

Formal landscape elements to define pedestrian routes and reinforce building geometry

Figure 51: Examples of landscape concepts in relationship to building types.

DESIGN CRITERIA

2. **Develop a landscape design concept that reinforces site design and fulfills the functional requirements of the development, including screening and buffering.**

INTENT

- To ensure that landscape design is an integral part of overall site design and reinforces site functions.
- To use landscape design to advantage in the economic revitalization of the corridor.
- To use landscape design to soften the transition between different land uses.

GUIDELINES

In addition to aesthetic goals, landscaping can fulfill a number of functional goals for a project. Consider the following in developing the landscape plan.

- a) Screening: Landscaping can provide for visual screening of incompatible adjacent land uses or activities, or between a heavily traveled street and a pedestrian walkway. It can also be used to screen service areas or other unattractive site or architectural features. Projects are encouraged in which landscaping is used to break up parking areas and screen parking areas from pedestrian walkways.
- b) Buffering: Using landscaping as a buffer can also reduce the impacts of wind, air pollution and noise on a development.
- c) Safety: Vertical plantings can be used to ‘mark’ a pedestrian walkway, making it more visible from parking areas or driveways. Landscape strips can be used to separate pedestrian areas from vehicle areas (see Criteria 1.F.1., “Site Design for Safety.”)
- d) Reducing Impacts of Development: Retaining existing vegetation can help reduce stormwater runoff and erosion (see Criteria 1.H.1. and 1.H.2., “Natural Features and Sensitive Areas” and 3.B.2., “Planting Design.”)
- e) Reducing Costs of Development: Landscaped areas can be used for water quality purposes, thereby reducing the long-term costs of site maintenance (see Criteria 1.I.1., “Stormwater Detention Facilities.”) Retaining existing vegetation, and therefore retaining existing topography and reducing grading and filling, generally results in lower land development costs (see Criteria 1.H.2. and 2.B.2. “Natural Features and Sensitive Areas.”)

Note: Refer to the Zoning Code for minimum landscaping, screening and buffering requirements.

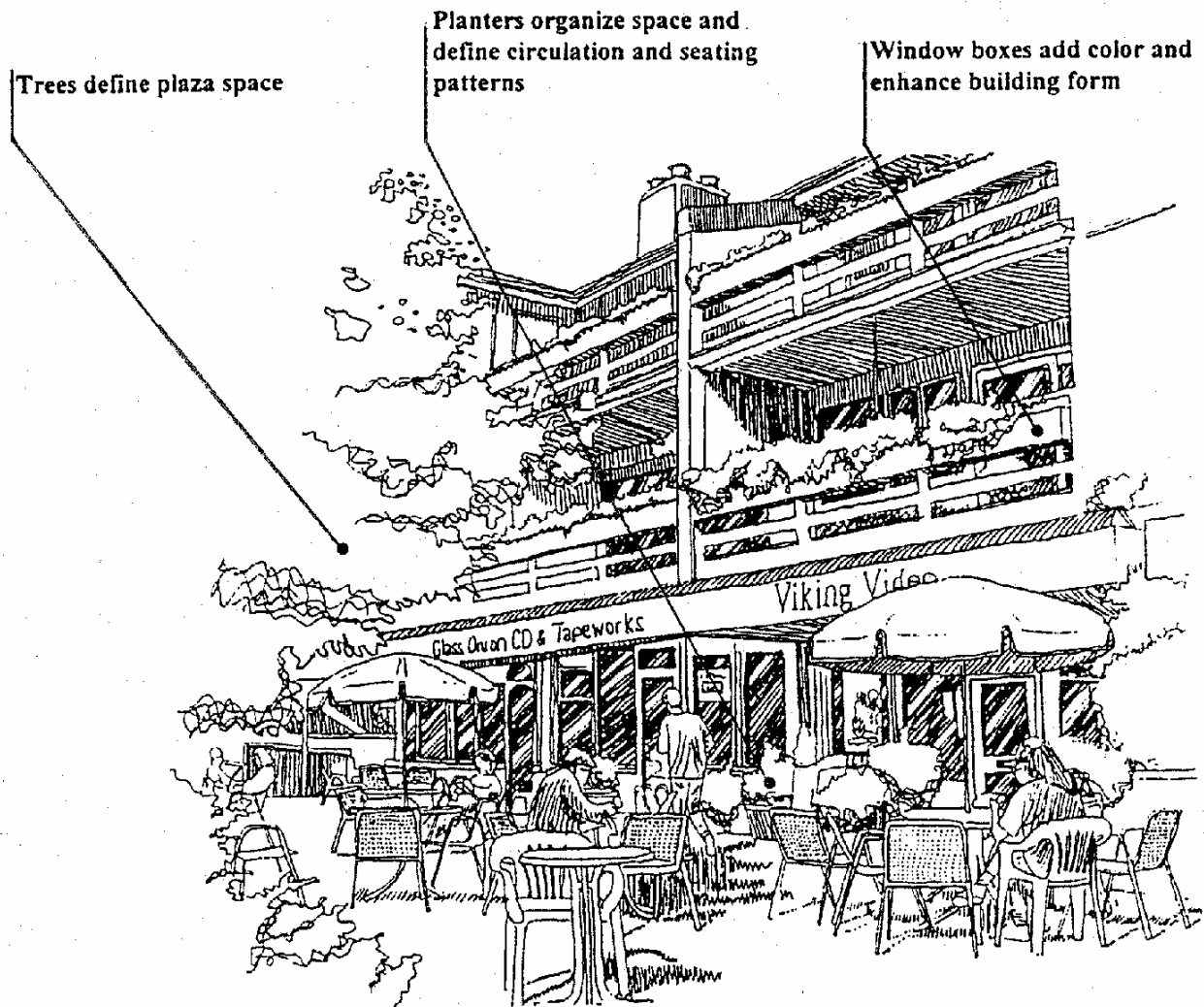

Figure 52: Landscape enhancements serve several purposes in this plaza.

DESIGN CRITERIA

- 3. Ensure that the landscape design reinforces and complements plantings in the public right-of-way.**

INTENT

- To achieve greater continuity and larger masses of plantings along the public right-of-way.
- To develop a greater sense of transition between public streetscape and the private landscape design.
- To improve the pedestrian environment.

GUIDELINES

One of the primary goals of the document is to improve the pedestrian and visual environment along Tukwila International Boulevard. Landscaping can play an important role in meeting this goal.

Plant materials must be selected from the Tukwila International Boulevard Plant List (see Appendix B) for landscaping the front landscape strip within the project property. Using plant materials from this list, or complementary plant materials, is also encouraged in any landscaped area visible from Tukwila International Boulevard.

Projects are encouraged in which a mix of shade trees, shrubs and groundcover is provided for every major landscape area on the site.

B. Planting Design

DESIGN CRITERIA

1. **Select plant materials that reinforce the landscape design concept, and are appropriate to their location in terms of hardiness, maintenance needs, and growth characteristics.**

INTENT

- To encourage selection of plant materials that will enhance the overall landscape design concept, and provide for variety and visual interest on the site.
- To encourage the use of plant materials that will survive with minimal or reasonable maintenance, are resistant to drought, and are otherwise appropriate for conditions.

GUIDELINES

Selected plant materials should include a suitable combination of trees, shrubs, and groundcover. Native and/or northwest adapted plants should be considered in selecting plant materials. The quantities, size, and arrangement of plant materials should be chosen with the goal of balancing color, texture, form, and scale in both the horizontal and vertical plane. The following design principles are guidelines for the selection and arrangement of plant materials:

- a) Unity: Select plant materials that contribute to the overall composition of the landscape design.
- b) Variety: Select a variety of plants with consideration of visual interest, plants as accents, and contrasting textures. Where feasible, coordinate selection of plant material to provide a succession of blooms and seasonal color.
- c) Consistency: Develop a planting design that complements overall project design, and provides continuity with plantings on adjoining lots, where appropriate.
- d) Appropriateness: Select plants with an awareness of their growth requirements, tolerances, ultimate size, preferences for soil and climate, and negative impacts. Use drought tolerant where appropriate.
- e) Density: Provide adequate plant quantity, size and spacing for the intended effect.

Note: Freestanding signs, either pole or monument, may be placed in front yard or side yard landscaping, provided they meet the provisions of the Tukwila Sign Code. Care should be taken in sign design, and the selection and maintenance of plant materials, to ensure that signs will not be obscured by the landscaping.

DESIGN CRITERIA

- 2. Incorporate existing significant trees, wooded areas, and/or vegetation in the planting plan where they contribute to overall landscape design.**

INTENT

- To conserve and enhance the aesthetic value of the area through the retention of mature vegetation.
- To retain a relationship between developed and existing natural areas.
- To take advantage of natural drainage and erosion control.
- To minimize maintenance costs.

GUIDELINES

Retain existing significant trees and vegetation on the site, provided that they are healthy and contribute to the overall landscape design.

Retaining existing non-native species (e.g., blackberries), insubstantial trees or vegetation is not encouraged. (Note: The best opportunity for using existing vegetation may be north of S. 140th Street, where trees and shrubs help stabilize steep banks).

Note: See Criteria 1.H.1., “Natural Features and Sensitive Areas” for additional guidance.

4. Signs

A. Signage Concept

DESIGN CRITERIA

1. **Provide signage that is integrated with the architectural concept in scale, detailing, use of color and materials, and placement.**

INTENT

- To employ signs as a positive element in site and building design, complementing the streetscape and private improvements.

GUIDELINES

Develop a signage scheme that complements the architecture of the building in design and placement. Ensure that all signs on the site are coordinated, and display similar or complementary design characteristics. The following are suggestions for integrating signage with the architectural concept:

- Locate signs on specific architectural elements, such as a canopy or fascia.
- Do not obscure important design features on building facades with signs.
- Coordinate color schemes or architectural details on signs, such as moldings, with the architectural scheme.
- Repeat specific architectural features, such as the roof form, in sign design.
- Emphasize special building features, such as an entry or display window, with properly scaled signage.

Note: These guidelines are to be used in conjunction with the Tukwila Sign Code (TMC Chapter 19); they do not supersede Sign Code regulations.

Don't



Dwarf the rest of building elements

Do

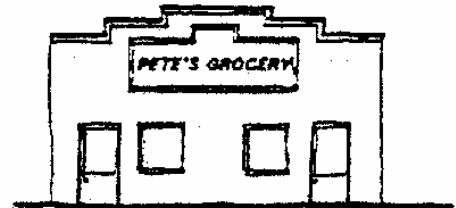

Keep with a reasonable scale relative to other elements



"Apply" sign indiscriminately to a building



Incorporate sign as part of building element such as awning or canopy

Figure 53: Positive and negative examples of integrating signage with architecture.

B. Sign Placement

DESIGN CRITERIA

- 1. Provide signage that is oriented to both pedestrians and motorists in design and placement.**

INTENT

- To provide signs that are easy to read for both motorists and pedestrians.
- To provide signage that is properly scaled for the purpose it is to serve, and the context within which it is placed.
- To help create a more pedestrian oriented environment in the Tukwila International Boulevard area.

GUIDELINES

Signs direct users to a site and within the site, and users are typically either driving or walking. Pedestrian-oriented signs are most effective when located within 15 feet of the ground plane. Three-inch-high letters can be read at 120 feet and six-inch letters can be read at 300 feet.

Consider the locations of sidewalks and pedestrian walkways in sign design, placement and illumination (see also Criteria 4.C.2., “Sign Design.”)

Automobile-oriented signs should be designed and sized with consideration for the length of time that the sign will be visible to motorists given the distance of the sign from the motorists, and the speed of travel.

DESIGN CRITERIA

- 2. Provide adequate directional signage on site and building identification numbers that are legible from the street(s).**

INTENT

- To enable customers, suppliers and emergency vehicles to easily find businesses and service areas.

GUIDELINES

Prominently display building numbers.

Provide on-site directional signage for vehicle drivers to identify destinations and to avoid conflicts with pedestrians.

Note: See Tukwila Sign Code for standards for internal information signs.

DESIGN CRITERIA

3. Integrate freestanding signs with the landscaping.

INTENT

- To coordinate signage with the landscaping.
- To provide a transition from the vertical elements of the freestanding sign to the horizontal site elements.
- To increase the prominence of site signage as viewed from the public street.
- To place signage where it is less easily damaged by vehicles.

GUIDELINES

Place plantings, including low shrubs, around the base of freestanding signs.

Freestanding signs, whether pole or monument signs, may be placed in front yard or side yard landscaping areas, provided they meet the provisions of the Tukwila Sign Code. Care must be taken in sign design and the selection and maintenance of plant materials so that the signs will not be obscured by the landscaping.

C. Sign Design

DESIGN CRITERIA

1. **Consider both day- and night-time viewing in the design, placement, and lighting of signage.**

INTENT

- To establish an attractive streetscape and safe conditions after dark.
- To avoid over-illumination of signs, creating a nuisance to surrounding residences.

GUIDELINES

Sign illumination should be appropriate for its intended purpose.

In general, direct lighting of signs creates a warmer, more pedestrian-friendly sign illumination; therefore, signs with front lighting and down lighting are recommended for pedestrian oriented signage.

Back-lighting generally is more appropriate for auto-oriented signs

Sign lighting should not cause glare or spillover onto neighboring properties.

Commercial signage should be placed facing away from residential properties and neighborhoods wherever possible.

Note: See Tukwila Sign Code for restrictions on sign design and placement.

DESIGN CRITERIA

2. **Provide durable, high quality materials and finishes for signage.**

INTENT

- To improve the visual quality of the Tukwila International Boulevard area.
- To encourage use of materials that are easily and inexpensively maintained.
- To improve the attractiveness of development along the Tukwila International Boulevard corridor.
- To prevent poor quality, poorly maintained signs and visual clutter on the highway.

GUIDELINES

The following guidelines are to aid in the selection of sign materials:

- a) Construct signs from durable materials and feature high-quality workmanship.

- b) Use borders, reveals, edging or other appropriate methods to prevent weather damage.
- c) Include the sign base and pole, associated lighting fixtures, and color choice as an integral part of a sign's design.
- d) Back-lit plastic, plywood, and sheet metal signs are discouraged.

Appendix A:

Definitions

Architectural Elements - As used in these guidelines, architectural elements refer to the elements that make up an architectural composition or the building form, and can include such features as the roof form, entries, an arcade, porch, columns, windows, doors and other openings. 'Architectural elements' is used interchangeably with architectural features in these guidelines.

Architectural Character - The architectural character of a building is that quality or qualities that make it distinctive and that are typically associated with its form and the arrangement of its architectural elements. For example the architectural character of a structure may be conveyed by a prominent design feature. Examples are a distinctive roof line, a turret or portico, an arcade, an elaborate entry, or an unusual pattern of windows and doors.

The architectural character may also be attributed to the building's style, which is typically conveyed by the architectural detailing associated with that style. For example, a building which is Neo-Classical in *style* may convey a formal architectural *character*.

Architectural Details - As used in these guidelines, architectural or building details refer to the minor building elements that contribute to the character or architectural style of the structure, and may include moldings, mullions, rooftop features, the style of the windows and doors, and other decorative features. As used in these guidelines, the architectural details that are used to *articulate* the structure may also include reveals, battens, and other three dimensional details that create shadow lines and break up the flat surfaces of a facade.

Architectural Form - As used in these guidelines, architectural form refers to the three dimensional shape of a structure, and is made up in part of the building elements.

Articulation - See *Architectural Details*.

Balcony - A balcony is an outdoor space built as an above ground platform projecting from the wall of a building and enclosed by a parapet or railing.

Bay Window - A bay window protrudes from the main exterior wall. Typically, the bay contains a surface that lies parallel to the exterior wall, and two surfaces that extend perpendicular or diagonally from the exterior wall.

Blank Walls - Walls subject to "blank wall" requirements are any ground level wall surface or section of a wall that is over six feet (6') in height measured from finished grade at the base of the wall, and longer than 50' measured horizontally, that does not have any significant building feature, such as a window, door, modulation or articulation, or other special wall treatment within that 50' section.

Courtyard - A courtyard is an open space, usually landscaped, that is enclosed on at least three sides by a structure or structures.

Curb Cut - A curb cut is a depression in the curb for the purpose of accommodating a driveway that provides vehicular access between private property and the street.

Deck - A deck is a roofless outdoor space built as an above-ground platform projecting from the wall of a building and supported by piers or columns.

Facade - A facade is any portion of an exterior elevation of a building extending from the grade of the building to the top of the parapet wall or eaves, for the entire width of the building elevation. A front facade is typically the facade facing the major public street(s). An entry facade is typically the facade with the primary public entry.

Foot-candle - A foot-candle is a unit used for measuring the amount of illumination on a surface. The amount of usable light from any given source is partially determined by the source's angle of incidence and the distance to the illuminated surface.

Frontage - As used in these guidelines, frontage refers to length of a property line along a public street or right-of-way.

Front Yard - As used in these guidelines, the front yard is the area between the street(s) and the nearest building facade.

Impervious Surface - Those hard surfaces that prevent or retard the entry of water into the soil in the manner that such water entered the soil under natural conditions prior to development; or a hard surface area that causes water to run off the surface in greater quantities or an increased rate of flow from the flow present under natural conditions, prior to development. Such surfaces include, but are not limited to, rooftops, asphalt or concrete paving, compacted surfaces, or other surfaces that similarly affect the natural infiltration or runoff patterns existing prior to development.

Lumen - A lumen is a unit used for measuring the amount of light energy given off by a light source.

Modulation - Modulation is a stepping back or projecting forward of portions of a building facade within specified intervals of building width and depth, as a means of breaking up the apparent bulk of a structure's continuous exterior walls. As used in these guidelines, the modulated portions must be at least 4 feet deep in order to qualify as modulation.

Pedestrian-Friendly Facades - "Pedestrian-friendly" facades are those that feature one or more of the following characteristics:

1. Transparent window area or window displays along at least half the length of the ground floor facade.

2. Sculptural, mosaic or bas-relief artwork along at least half the length of the ground floor facade.
3. "*Pedestrian-Oriented Space*" - As defined below. At least 500 SF must be located along or adjacent to the public or private sidewalk(s), for every 100 linear feet of ground floor facade that faces the public street(s).
4. Other measures that meet the intent of the criteria, as approved in conjunction with overall design review approval.

Pedestrian-Oriented Space - A pedestrian-oriented space is an area between a building and a public street that promotes visual and pedestrian access onto the site and that provides pedestrian-oriented amenities and landscaping that enhances the public's use of the space. To qualify as a "*pedestrian-oriented space*," an area must have:

- Visual and pedestrian access into the site from the public right-of-way,
- Paved walking surfaces of either concrete or approved unit paving,
- On-site or building-mounted lighting providing at least 2 foot candles (avg.) on the ground, and
- Seating; at least 2' of seating area (bench, ledge, etc.) or one individual seat per 60 SF of plaza area or open space.

A "*pedestrian-oriented space*" is encouraged to have:

- Landscaping that does not act as a visual barrier.
- Site furniture, artwork or amenities such as fountains, kiosks, etc.
- Pedestrian weather protection or other enclosure, such as an arcade or gazebo.

A "*pedestrian-oriented space*" shall not have:

- Asphalt or gravel pavement.
- Adjacent unscreened parking lots.
- Adjacent chain-link fences.
- Adjacent "*blank walls*" without "*blank wall treatment*."

Scale, Human - The size of a building element or space relative to the dimensions and proportions of the human body.

Scale, Architectural - The perceived height and bulk of a building relative to other forms in its context. A building's apparent height and bulk may be reduced by modulating facades and other treatments.

Service Areas - Service areas refer broadly to the areas, whether enclosed or open that contain such equipment and uses as ground level mechanical equipment, utility vaults, loading zones, outdoor storage areas, and trash and recycling areas.

Site Planning - Site planning is the arrangement of buildings, driveways, sidewalks, landscaping, parking, public open spaces, and other facilities on a specific site. Good site planning will display a cohesive site design concept, and take into consideration natural features, topography, drainage requirements, access points, the design of neighboring sites, and other features in the immediate vicinity of the site.

Streetscape - The streetscape is the visual character and quality of a street as determined by various elements located between the edge of the street and the building face, such as trees and other landscaping, street furniture, artwork, transit stops, utility fixtures and equipment, and paving. Where there are frequent and wide spaces between buildings, the streetscape will be defined by the pattern of building and open space and the character of that open space.

APPENDIX B:

TUKWILA INTERNATIONAL BOULEVARD PLANT PALETTE

(To be developed in conjunction with public streetscape improvements.)